

OPERATION AND MAINTENANCE MANUAL FOR MODELS MRV040A REVERSIBLE AIR MOTOR

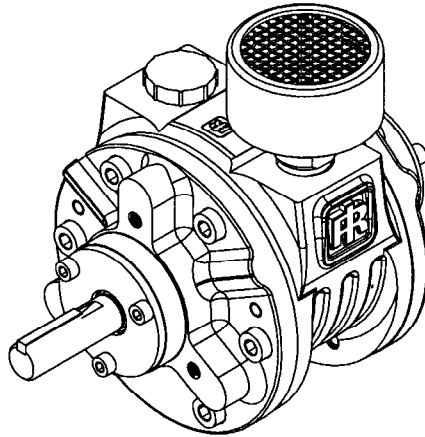

TPM_1038

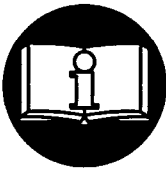

⚠ WARNING

**IMPORTANT SAFETY INFORMATION ENCLOSED.
READ THIS MANUAL BEFORE OPERATING TOOL.**

FAILURE TO OBSERVE THE FOLLOWING WARNINGS COULD RESULT IN INJURY.

- Always operate, inspect and maintain this motor in accordance with American National Standards Institute Safety Code for Portable Air Tools (ANSI B186.1).
- For safety, top performance and maximum durability of parts, operate this motor at 90 psig (6.2 bar/620 kPa) air pressure at the inlet with 1/2" (12.7 mm) air supply hose.
- Always turn off the air supply and disconnect the air supply hose before installing, removing or adjusting any accessory on this motor or before performing any maintenance on this motor.
- Keep hands, loose clothing and long hair away from rotating end of motor.
- Anticipate and be alert for sudden changes in motion during start up and operation of any motor.
- Motor shaft may continue to rotate briefly after throttle is released.
- Do not lubricate motor with flammable or volatile liquids such as kerosene, diesel or jet fuel.
- Do not remove any labels. Replace any damaged label.
- Use accessories recommended by Ingersoll-Rand.
- This motor is not designed for working in explosive atmospheres.
- This motor is not insulated against electric shock.

NOTICE

The use of other than genuine Ingersoll-Rand replacement parts may result in safety hazards, decreased tool performance and increased maintenance, and may invalidate all warranties.

Ingersoll-Rand is not responsible for customer modification of tools for applications on which Ingersoll-Rand was not consulted.

Repairs should be made only by authorized, trained personnel. Consult your nearest Ingersoll-Rand Authorized Servicerenter.

It is the responsibility of the employer to place the information in this manual into the hands of the operator.

WARNING LABEL IDENTIFICATION

⚠ WARNING

FAILURE TO OBSERVE THE FOLLOWING WARNINGS COULD RESULT IN INJURY.

	⚠ WARNING
	Always wear eye protection when operating or performing maintenance on this motor.

	⚠ WARNING
	Always wear hearing protection when operating this motor.

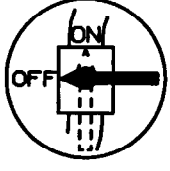
	⚠ WARNING
	Always turn off the air supply and disconnect the air supply hose before installing, removing or adjusting any accessory on this tool, or before performing any maintenance on this motor.

	⚠ WARNING
	Do not use damaged, frayed or deteriorated air hoses and fittings.

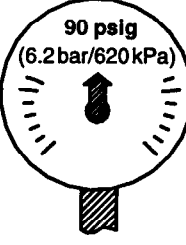
	⚠ WARNING
	Operate at 90 psig (6.2 bar/620 kPa) Maximum air pressure.

PLACING TOOL IN SERVICE

LUBRICATION



Ingersoll-Rand No. 10



Ingersoll-Rand No. 28

Always use an air line lubricator with this motor. We recommend the following Filter-Lubricator-Regulator Unit:

No. C28-04-FKGO-28

Where the lubricator cannot be permanently mounted, use Ingersoll-Rand No. 3LUB8 Lubricator.

We recommend the use of an air line lubricator in the air supply line. Attach the unit as close to the motor as practical. For permanent installations, we recommend using an Ingersoll-Rand C28-04-FKGO-28

Filter-Lubricator-Regulator Unit. These units have 1/2" pipe tap inlet and outlet. The 3LUB8 has 1/6 pt (79 mL) capacity; the C28-04-FKGO-28 has 1/2 pt (237 mL) capacity. Other units may be used, but do not use a unit having less than 1/2" NPT inlet and outlet.

OPERATION INSTRUCTIONS

If the motor operates sluggishly, flush it with a clean, non-toxic, nonflammable commercial solvent in a well ventilated area. To flush the motor, disconnect the air line and muffler, and pour 6 or 8 cc of solvent into each inlet. Rotate the rotor shaft by hand in both directions several times to assure that all the internal parts are thoroughly cleaned. Attach the air hose and while keeping your face away from the exhaust air, slowly increase the air flow until there is no trace of the solvent in the exhaust. After flushing, shut off the air supply and disconnect the air hose. Pour 6 or 8 cc of a high detergent SAE 10 motor oil into the air inlet side of the motor, and reconnect the air supply line and muffler. Increase the air flow slowly so that the internal parts of the motor will be covered with a film of oil.

If the motor is still low in power, check for damaged Vanes or foreign material in the vane slots in the Rotor.

VANE REPLACEMENT

Vanes will last 5,000 to 15,000 hours of operation, depending upon the speed of the motor, operating pressure, lubrication and preventative maintenance.

Periodically, you should check the Vanes for wear, and replace them if the width of the Vane is equal to or less than the replacement width shown below:

- Width of new Vane 13/16 inch
- Replacement width 25/32 inch

Always replace Vanes in sets; never replace an individual Vane. Replace Vanes as follows:

1. Disconnect the air line at the motor.
2. Unscrew and remove the the Rear End Cap Screws and Rear End Cap.
3. Unscrew and remove the Rear End Plate Cap Screws.
4. Using a puller, pull the Rear End Plate along with the Rear Rotor Bearing from the motor.
5. Wipe each of the new vanes to be installed with a thin film of light oil.
6. Rotate the Rotor by hand to place two of the Vanes in a horizontal position.
7. Obtain a stiff piece of wire or length of key stock that will slide into the vane slots, and grind one end of it to a gentle, sloping bevel. You will use this for depressing the Vane Pins while changing Vanes.
8. Insert the depressing tool in the vane slot along the bottom edge of the Vane so that it passes between the Vane and the Vane Pin.
9. Depress the Vane Pin toward the center of the Rotor and, while holding it in this position, withdraw the worn Vane and install the new Vane with its notched side toward the center of the Rotor.
10. Repeat the procedure with each Vane.

NOTICE

The use of other than genuine Ingersoll-Rand replacement parts may result in decreased tool performance and increased maintenance, and may invalidate all warranties.

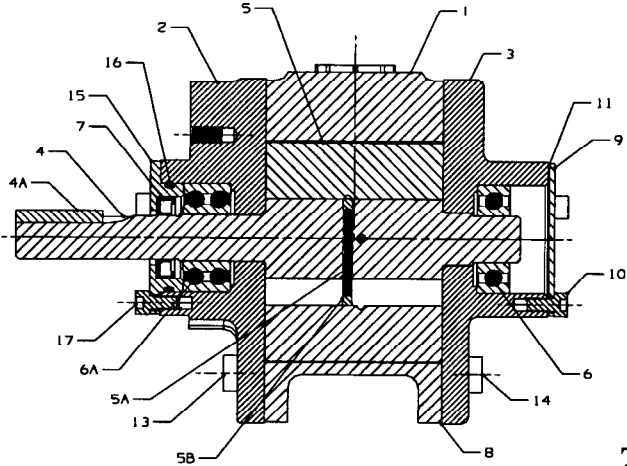
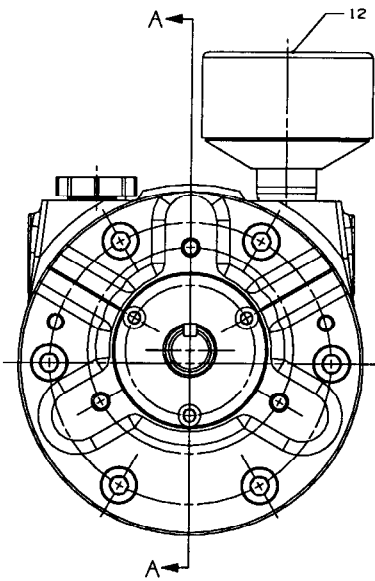

TPM_1039

PART NUMBER FOR ORDERING



1	Cylinder	**
2	Front End Plate	**
3	Rear End Plate	**
4	Rotor	**
4A	Drive Key	**
5	Vane (4)	**
5A	Vane Spring (2)	**
5B	Vane Pin (4)	**
6	Rear Rotor Bearing	**
6A	Front Rotor Bearing	**
7	Rotor Shaft Seal	**
8	End Plate Gasket (2)	**
9	Rear End Cap	**
10	Rear End Cap Screws	**
11	End Cap Gasket	**
12	Muffler Assembly	MRV040A-AC990
*	Muffler Screen (2)	**
*	Muffler Felt	**
13	Front End Plate Cap Screw (6)	**
14	Rear End Plate Cap Screw (6)	**
15	Shield	**
16	O-Ring	**
17	Shield Cap Screws	**
*	Mounting Foot	MRV040A-AH634
*	NEMA Mounting Flange	MRV040A-AH633
*	Tune-up Kit (includes illustrated parts 5, 5A, 5B, 6, 6A, 7, 8 and 11)	MRV040A-TK1

* Part not shown

** Parts not sold separately (only sold in complete Motor or Tune-Up Kit)

MAINTENANCE SECTION

WARNING

Always wear eye protection when operating or performing maintenance on this motor.

Always turn off air supply and disconnect supply hose before installing, removing or adjusting any accessory on this motor, or before performing any maintenance on this motor.

DISASSEMBLY

General Instructions

1. Always disconnect the air line at the motor before attempting any disassembly.
2. Do not disassemble the motor any further than necessary to replace or repair damaged parts.
3. The Vanes are spring loaded. Do not withdraw the Rotor from the Cylinder unless it is absolutely necessary. Vanes can easily be replaced without withdrawing the Rotor. (see "Vane Replacement" section)
4. When grasping a part in a vise, always use leather-covered or copper-covered vise jaws to protect the surface of the part and help prevent distortion. This is particularly true of threaded members and housings.
5. Do not remove any part which is a press fit in or on a subassembly unless the removal of that part is necessary for repairs or replacement.
6. Important: After these motors were assembled at the factory, Cylinder Dowel alignment pins were pressed into the End Plates and Cylinder. During disassembly, these pins will usually remain with the Cylinder. Do not remove them.

Disassembly of the Rear End Plate

1. Unscrew and remove the Rear End Cap Screws and remove the Rear End Cap (9).
2. Unscrew and remove the Rear End Plate Screws (14).
3. Using a puller, pull the Rear End Plate (3) along with the Rear Rotor Bearing (6) from the motor.
4. The Rear Rotor Bearing is a slip fit in the Rear End Plate. Slide or push it from the bearing recess.

Disassembly of the Front End Plate

1. Unscrew the Front End Plate Cap Screws (13).
2. Using a puller, pull the Front End Plate (2) along with the Front Rotor Bearing (8A) from the rotor shaft.

3. The Rotor Shaft Seal (7) is pressed into Shield (15). Do not remove these parts unless you have a new Seal on hand. This Seal is always destroyed in the removal process. If you have to remove the Rotor Shaft Seal, unscrew and remove the Shield Cap Screws (17). Pull the Shield from the Front End Plate. If you have to remove the Rotor Shaft Seal, pry it out of the Shield with a large screwdriver.
4. The Front Rotor Bearing is a slip fit in the Front End Plate. Slide or push it from the bearing recess.
5. Carefully remove O-Ring (16) from Shield, taking care not to cut o-ring.

Removal of the Rotor

1. If the Rotor (4) must be withdrawn from the Cylinder, remove the Rear End Plate as previously described.
2. Unscrew the Front End Plate Cap Screws.
3. Carefully withdraw the assembled Front End Plate and Rotor from the Cylinder. Caution: As you withdraw the Rotor, grasp the rotor body so that the Vanes (5), Vane Springs (5A) and Vane Pins (5B) do not fly.
4. After withdrawing the Rotor, remove the Vanes, Vane Springs and Vane Pins.
5. Support the Front End Plate as close to the rotor body as possible, and press the Rotor from the Front Rotor Bearing.

ASSEMBLY

General Instructions

1. Always wipe all parts with a thin film of oil before installing them in the motor.
2. Always press on the **inner ring** of a ball-type bearing when installing the bearing on a shaft.
3. Always press on the **outer ring** of a ball-type bearing when pressing the bearing into a bearing recess.
4. Whenever grasping a part in a vise, always use leather-covered or copper-covered vise jaws to protect the surface of the part and help prevent distortion. This is particularly true of threaded members and housings.

Assembly of the Rear End Plate

1. Support the Motor on the Front End Plate (2).
2. Place End Plate Gasket (8) on the rear face of the Cylinder (1), making certain that it is properly oriented relative to the Cylinder Dowels and tapped holes in the Cylinder.

MAINTENANCE SECTION

NOTICE

If you are installing a new Gasket, you will have to punch or cut two holes in it to accommodate the Cylinder Dowels. Do this by placing the Gasket on the Gasket on the Rear End Plate to determine the location of the dowel holes. Use a proper size gasket punch to cut the required dowel holes.

3. Align the dowel holes in the Rear End Plate (3) with Cylinder Dowels in the Cylinder and, using a plastic hammer, tap the Rear End Plate into place against the Gasket.
4. Using a sleeve that contacts only the inner ring of the Bearing, press the Rear Rotor Bearing (6) onto the rotor shaft until it seats in the bearing recess in the Rear End Plate.

CAUTION

Do not bind the End Plate against the Rotor.

5. Rotate Rotor (4) by hand. It should rotate freely with no binding or rubbing against the Cylinder. If the Rotor rubs or binds, tap the top edge of the Rear End Plate with a plastic hammer in the area midway between the inlet and outlet ports. Tap the End Plate gently. The Rotor needs only .0015" clearance from the top of the Cylinder. If the Rotor continues to rub, it may be contacting the Front End Plate due to pressing on the Rear Rotor Bearing. Lightly tap the keyed end of the rotor shaft with a plastic hammer. The rotor needs about .002" clearance between the rotor body and each End Plate.
6. When the Rotor turns freely, install the End Plate Cap Screws (14). Tighten them to 8 to 10 ft-lb (10.8 to 13.5 Nm).
7. Slip End Cap Gasket (11) on the end of Rear End Plate (3). Place the Rear End Cap over the Gasket and Screw the Rear End Cap Screws (10) into the Rear End Plate. Tighten to 8 to 10 ft-lb (10.8 to 13.5 Nm).

Assembly of the Front End Plate

1. Support the Motor on the Rear End Plate.
2. Place an End Plate Gasket on the front face of the Cylinder, making certain that is properly oriented relative to the Cylinder Dowels and tapped holes in the Cylinder.

NOTICE

If you are installing a new Gasket, you will have to punch or cut two holes in it to accommodate the Cylinder Dowels. Do this by placing the Gasket on

the Gasket on the Rear End Plate to determine the location of the dowel holes. Use a proper size gasket punch to cut the required dowel holes.

3. Align the dowel holes in the Front End Plate with the Cylinder Dowels in the Cylinder and, using a plastic hammer, tap the Front End Plate into place against the Gasket.
4. Using a sleeve that contacts only the inner ring of the Bearing, press the Front Rotor Bearing (6A) onto rotor shaft until it seats in the bearing recess in the Front End Plate.
5. Rotate the Rotor by hand. It should rotate freely with no binding or rubbing against the Cylinder. If the Rotor rubs or binds, tap the top edge of the Front End Plate with a plastic hammer in the area midway between the inlet and outlet ports. Tap the End Plate gently. The Rotor needs only .0015" clearance from the top of the Cylinder. If the Rotor continues to rub, it may be contacting the Rear End Plate due to pressing on the Front Rotor Bearing. Remove the Rear End Cap and lightly tap the end of the rotor hub with a plastic hammer. The Rotor needs about .002" clearance between the rotor body and each End Plate.
6. When the Rotor turns freely, install the Front End Plate Cap Screws (13). Tighten them to 8 to 10 ft-lb (10.8 to 13.5 Nm).
7. Moisten the lip of a new O-Ring (16) and slip onto groove on Shield (15). Press Seal (7) into Shield (15) to bottom of recess.
8. Moisten the lip of a new Rotor Shaft Seal (9) and O-Ring (16) with O-Ring lubricant and press the Shield into the Front End Plate.
9. Install the Shield Screws. Tighten to 8 to 10 ft-lb (10.8 to 13.5Nm).

Assembly of the Motor

1. Position the Rotor vertically on the table of an arbor press so that the short hub is upward.
2. Place the Rear End Plate, flat side first, on the short hub of the Rotor.
3. Place a .002" thick shim on each side of the Rotor between the rotor body and the Rear End Plate.
4. Using a sleeve that contacts only the inner ring of the Bearing, press the Rear Rotor Bearing (8) onto the hub of the Rotor until it seats in the bearing recess in the Rear End Plate.
5. Withdraw the shims.
6. Stand the assembled Rotor and End Plate upright on on the hub of the Rear End Plate.
7. Place a Vane Spring (5A) in the center of each cross-hole in the rotor body. Place a Vane Pin (5B) at each end of each Vane Spring.

MAINTENANCE SECTION

Assembly of the Motor

8. Moisten each Vane (5) with film of light oil.
9. Place a Vane, notched side first, in each vane slot.
10. Place a rubber band around the rotor body to hold the Vanes, Vane Springs and Vane Pins in place.
11. Place an End Plate Gasket on the rear face of the Cylinder, making certain that it is properly oriented relative to the Cylinder Dowels and tapped holes in the Cylinder

NOTICE

If you are installing a new Gasket, you will have to punch or cut two holes in it to accommodate the Cylinder Dowels. Do this by placing the Gasket on the Rear End Plate to determine the location of the dowel holes. Use a proper size gasket punch to cut the required dowel holes.

12. Slide the assembled Rotor and Rear End Plate into the Cylinder until the End Plate contacts the Cylinder Dowels.
13. Using a wire hook inserted between the End Plate Cylinder, pull the rubber band free of the rotor, thus leaving the Vanes, Vane Springs and Vane Pins trapped in the Cylinder.
14. Align the dowel holes in the Rear End Plate with the Cylinder Dowels in the Cylinder and, using a plastic hammer, tap the Rear End Plate into place against the Gasket.
15. Install the Front End Plate as described in Steps 1, 2, 3 and 4 in the section titled Assembly of the Front End Plate.
16. Rotate the Rotor by hand. It should rotate freely with no binding or rubbing against the Cylinder. If the Rotor rubs or binds, tap the top edge of the Rear End Plate with a plastic hammer in the area midway between the inlet and outlet ports. Tap the End Plates gently. The Rotor needs only .0015" clearance from the top of the Cylinder. If the Rotor continues to rub, it may be contacting the Rear End Plate due to pressing on the Front Rotor Bearing. Lightly tap the end of the rotor hub with a plastic hammer. The Rotor needs about .002" clearance between the rotor body and each End Plate.
17. When the Rotor turns freely, install the End Plate Cap Screws (13,14) and tighten them to 8 to 10 ft-lb (10.8 to 13.5 Nm).
18. Install the Rotor Shaft Seal (7), Shield and Front End Cap as described in Step 8 in the section titled Assembly of the Front End Plate.
19. Install the Rear End Cap (9) as described in Step 7 in the section titled Assembly of the Rear End Plate.
20. Again, check the Rotor to see that it rotates freely. Make certain it is rotating freely before connecting the air supply line.

TROUBLESHOOTING GUIDE

Trouble	Probable Cause	Solution
Low power or low free speed	Low air pressure at the inlet	Check air pressure at the inlet. For top performance and durability of parts, the air pressure must be 90 psig (6.2 bar/620 kPa) at the inlet.
	Worn or broken Vanes	Install a new set of Vanes.
	Improper lubrication or dirt building up in the Motor	Lubricate as instructed under LUBRICATION. If this does not help, flush the Motor as instructed under OPERATION.
Rough operation	Worn or broken Rotor Bearings	Examine each Bearing. Install new bearing where necessary.
Scoring of End Plates and/or Cylinder	Rotor does not have proper clearance	Refer to Assembly of Motor section. (Step 16)

MRV040A Motor Dimensions

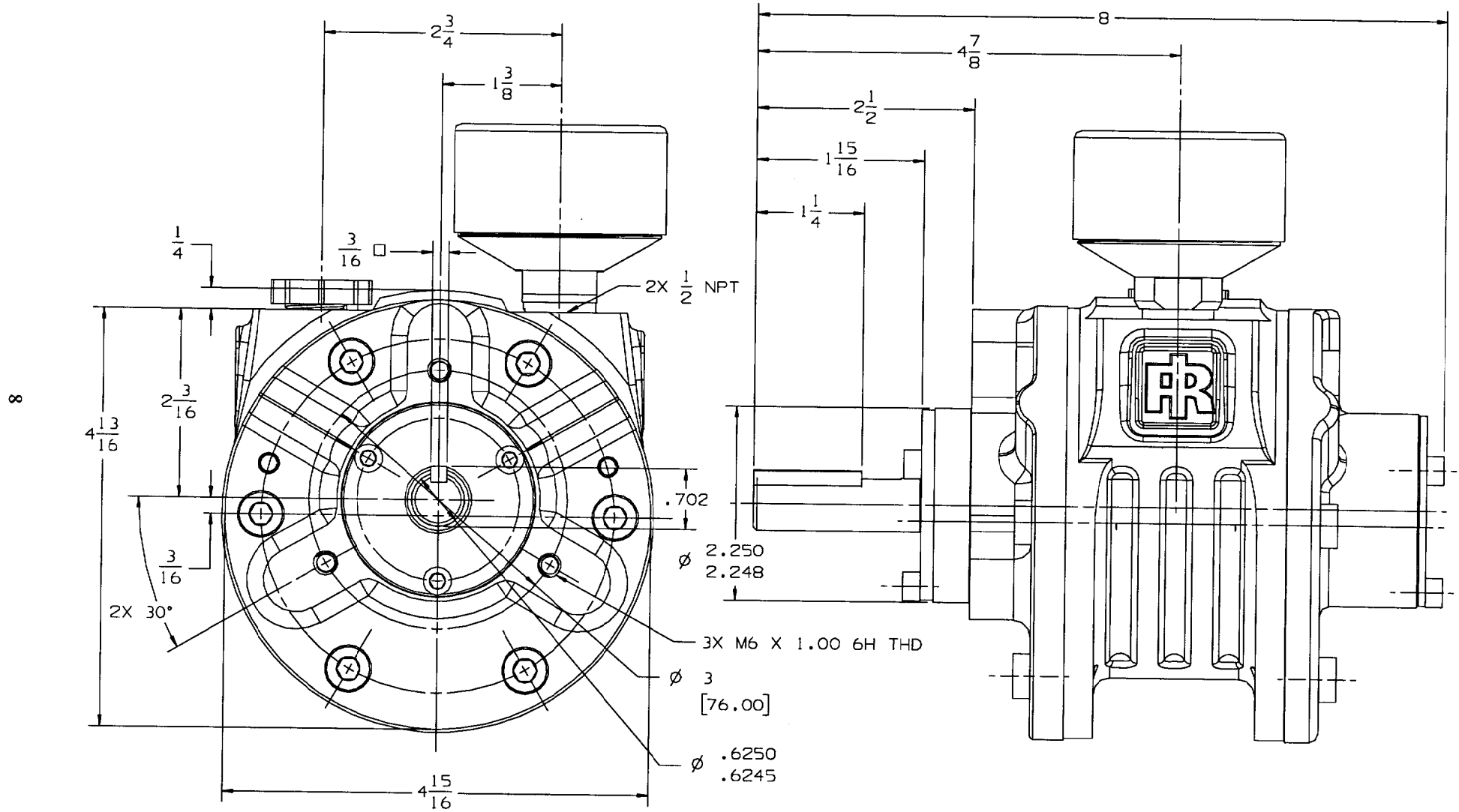

NOTES

NOTES

NOTES