

OPERATOR'S MANUAL

SB30X-X

INCLUDING: OPERATION, INSTALLATION & MAINTENANCE

RELEASED: 2-18-00
 REVISED: 5-20-05
 (REV. D)

3" SHOCK BLOCKER® METALLIC PULSATION DAMPENER



**READ THIS MANUAL CAREFULLY BEFORE INSTALLING,
 OPERATING OR SERVICING THIS EQUIPMENT.**

It is the responsibility of the employer to place this information in the hands of the operator. Keep for future reference.

SERVICE KITS

Refer to Model Chart to match the pump material options.
 637330-3X for repair of the diaphragm and "O" rings (see page 4).

PUMP DATA

Models	see Model Description Chart for "-XXX-X".
Pulsation Dampener Type	Metallic
Material	see Model Description Chart.
Weight ..	SB30X-XAX-X 41 lbs (18.6 kgs)
	SB30X-XCX-X 94 lbs (42.6 kgs)
	SB30X-XSX-X 96 lbs (43.5 kgs)
Material Inlet / Outlet ..	SB30X- <u>A</u> XX-X .. 3 - 8 N.P.T. - 1
	SB30X- <u>B</u> XX-X .. Rp 3 (3 - 11 BSP parallel)
Air Inlet (female)	3/4 - 14 N.P.T.
Maximum Air Inlet Pressure	120 p.s.i.g. (8.3 bar)
Maximum Material Inlet Pressure	120 p.s.i.g. (8.3 bar)
Maximum Temperature Limits (diaphragm / seal material)	
E.P.R. / EPDM	-60° to 280° F (-51° to 138° C)
Nitrile	10° to 180° F (-12° to 82° C)
Santoprene®	-40° to 225° F (-40° to 107° C)
T.F.E. (Teflon®)	40° to 225° F (4° to 107° C)
Viton®	-40° to 350° F (-40° to 177° C)
Maximum Fluid Volume	509 in. ³ (8.34 lit.)
Dimensional Data	see page 7.

NOTICE: All possible options are shown in the chart, however, certain combinations may not be recommended, consult a representative or the factory if you have questions concerning availability.

3" PULSATION DAMPENER
 SB30X-XXX-X

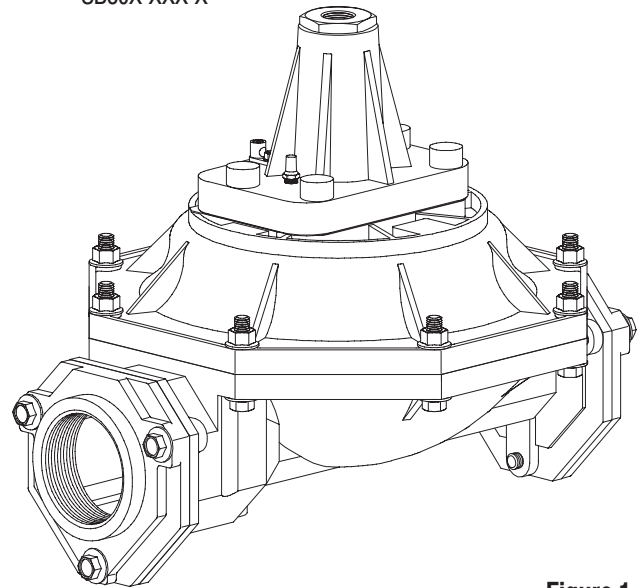

Figure 1

MODEL DESCRIPTION CHART

	SB30	X	X	X	X
VALVE BODY / AIR CAP MATERIAL	A	S			
A - Aluminum					
S - Stainless Steel					
THREAD	A	B			
A - N.P.T.					
B - BSP					
FLUID CAPS MATERIAL	A	C	S		
A - Aluminum					
C - Cast Iron					
S - Stainless Steel					
HARDWARE MATERIAL	P	S			
P - Plated Steel					
S - Stainless Steel					
DIAPHRAGM MATERIAL	A	G	T	V	
A - Santoprene					
G - Nitrile					
T - Teflon / Santoprene					
V - Viton					
FLUID SECTION SERVICE KIT SELECTION	SB30X - XXX - X				
EXAMPLE: MODEL # SB30A-BAP-G	637330 - 3 X				
FLUID SECTION SERVICE KIT # 637330-3G	Diaphragm				

Shock Blocker® is a registered trademark of the ARO Corporation.

OPERATING AND SAFETY PRECAUTIONS

READ, UNDERSTAND, AND FOLLOW THIS INFORMATION TO AVOID INJURY AND PROPERTY DAMAGE.

⚠️ WARNING EXPLOSION HAZARD. Do not exceed maximum fluid inlet pressure of 120 p.s.i. (8.3 bar). Operating at higher pressure can cause explosion resulting in property damage or severe injury.

⚠️ WARNING USE ONLY WITH COMPRESSED AIR. Do not use bottled gas products to run the pulsation dampener. Unregulated high pressure bottled gas has the potential for over-pressurization. Certain gasses such as Nitrogen can cause unpredictable results. The pressure source MUST BE REGULATED.

⚠️ WARNING CHEMICAL COMPATIBILITY HAZARD. Do not use with certain fluids. Incompatible fluids may attack and weaken the housing causing rupture or explosion which can result in property damage or severe injury. See manufacturers information on fluid compatibility.

⚠️ WARNING DISASSEMBLY HAZARD. Do not disassemble this unit when it is under pressure. Relieve all material pressure in the pumping system before attempting service or disassembly. Disconnect air lines and carefully bleed any pressure off the system. Be certain the system is not maintaining pressure due to a material restriction in the hose, line, dispensing device, or the spray or extrusion tip. Failure to relieve pressure both up stream and downstream may result in an injury upon disassembly.

⚠️ CAUTION AIR MUST BE SUPPLIED TO THE SHOCK BLOCKER BEFORE APPLYING FLUID PRESSURE. Failure to pressurize with air first can damage the diaphragm.

⚠️ CAUTION ALWAYS RELIEVE THE FLUID PRESSURE BEFORE REMOVING THE AIR PRESSURE. Failure to relieve fluid pressure can damage the diaphragm.

⚠️ CAUTION NOT FOR STRUCTURAL SUPPORT. Do not use this product to support other system components or use as a step. Improper support can result in fracture of the housing causing damage. Plumbing must be supported to prevent stresses upon it.

NOTICE Replacement warning labels are available upon request: "Static Spark & Diaphragm Rupture" pn \ 94080.

⚠️ WARNING = Hazards or unsafe practices which could result in severe personal injury, death or substantial property damage.

⚠️ CAUTION = Hazards or unsafe practices which could result in minor personal injury, product or property damage.

NOTICE = Important installation, operation or maintenance information.

OPERATING INSTRUCTIONS

⚠️ WARNING HEED WARNINGS AS SHOWN IN "OPERATING AND SAFETY PRECAUTIONS" ABOVE.

AIR REQUIREMENTS

Supply the unit with clean, dry air.

A filter capable of filtering out particles larger than 50 microns should be used on the air supply.

INSTALLATION INSTRUCTIONS

Position the Shock Blocker pulsation dampener as close to the pump discharge as possible (as shown in figure 2).

⚠️ CAUTION SUPPORT THE PIPE IMMEDIATELY DOWNSTREAM FROM THE SHOCK BLOCKER. Support is required to eliminate forces and moments from the Shock Blocker flanges and pump manifold. Cantilever support is suggested immediately downstream from the Shock Blocker.

Use a tee connector after the F-R-L on the pump air supply line and connect the line to the Shock Blocker's valve body (1/4" i.d. hose is sufficient). When the air supply to the pump is shut down, the air to the Shock Blocker will be shut down as well.

TYPICAL SYSTEM INSTALLATION

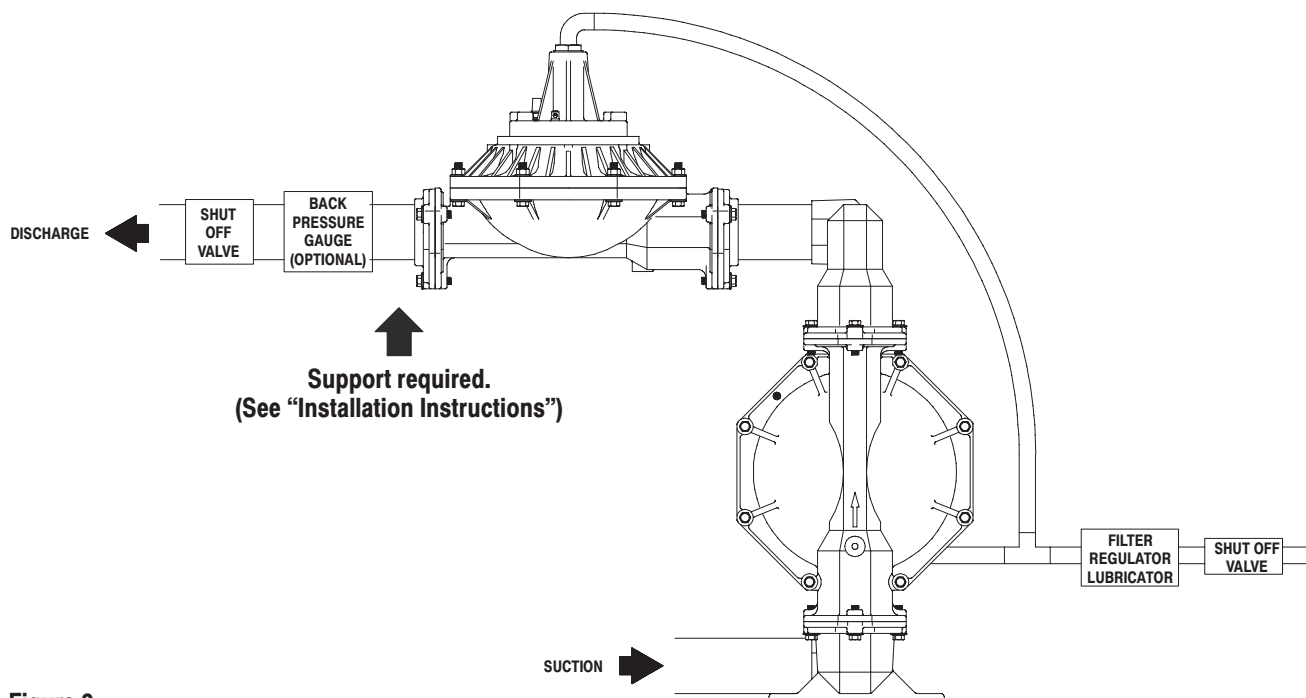

Figure 2

GENERAL DESCRIPTION

The ARO Shock Blocker, pulsation dampener is designed to work with 1:1 ratio pumps having an outlet pressure not exceeding 120 p.s.i. (8.3 bar). The Shock Blocker will effectively reduce material pressure variations, surges and shock to piping and delivery in fluid systems during pump reversal. It can significantly contribute to pulse reduction in low pressure spray applications.

Accurate selection of wetted material will assure longest service life and minimize down time. Several material options are available for the body and diaphragm materials. Fluid section materials available include: Aluminum, Cast Iron and Stainless Steel. For specific fluid compatibility, consult the chemical manufacturer.

The Shock Blocker uses a single air pressurized, flexible diaphragm working against the fluid line pressure. Several diaphragm material options are available to allow custom matching to the fluid material for best compatibility (refer to the model description chart).

Shock Blocker units can also be added in series to provide additional dampening on the material.

Pressure relief through the exhaust port is a normal compensating function of the control valve in the Shock Blocker. It will automatically adjust itself to the required operating pressure once the material pressure has been applied. The air pressure supplied to the Shock Blocker needs to be equal to the material pressure to provide the proper dampening effect.

AIR AND LUBE REQUIREMENTS

⚠ WARNING EXCESSIVE AIR PRESSURE. Can cause pulsation dampener damage, personal injury or property damage.

- A filter capable of filtering out particles larger than 50 microns should be used on the air supply. There is no lubrication required other than the “O” ring lubricant which is applied during assembly or repair.
- If lubricated air is present, make sure that it is compatible with the Nitrile “O” rings in the air motor section of the pump.

OPERATION

⚠ CAUTION DO NOT EXCEED 120 P.S.I. (8.3 BAR). Operating at higher pressure can cause explosion, resulting in property damage or severe injury.

- Pressure relief through the exhaust port is a normal compensating function of the control valve in the Shock Blocker. It will automatically adjust itself to the required operating pressure once the material pressure has been applied.
- Operate the system for a few minutes to equalize air and fluid chambers of the pulsation dampener.

PARTS AND SERVICE KITS

Refer to the part views and descriptions as provided on pages 4 and 5 for parts identification and Service Kit information.

- Certain ARO “Smart Parts” are indicated which should be available for fast repair and reduction of down time.

MAINTENANCE

- Provide a clean work surface to protect sensitive internal moving

parts from contamination from dirt and foreign matter during service disassembly and reassembly.

- Keep good records of service activity and include pump in preventive maintenance program.
- Before disassembling, empty captured material in the fluid cap by tipping the pulsation dampener on end.

FLUID SECTION DISASSEMBLY

1. Remove (107) reducing bushing.
2. Remove six (26) screws, releasing two (4) flanges and (11) “O” rings.
3. Remove eight (27) screws and (29) nuts, releasing (15) fluid cap.
4. Secure (14) screw in a vise, with (101) air valve body upward.
5. Using a 15/16” socket on (186) screw, unthread and remove (186) screw and (10) washer.
6. Remove (68) air cap from (7) diaphragm and components.
7. Remove (14) screw from the vise. Unthread and remove (1) rod, releasing (2) stopper, (5) back-up washer, (196) cushion, (7) or (7 and 8) diaphragms, (6) washer, (3) “O” ring and (9) washer from (14) screw.
8. Remove four (131) screws, releasing (101) air valve body from the (68) air cap.
9. Remove (144) “U” cup from (68) air cap.
10. Remove (103) sleeve from (101) air valve body.

FLUID SECTION REASSEMBLY

- Clean and inspect all parts. Replace worn or damaged parts with new parts as required. Lubricate all replacement parts and metallic moving parts with Lubriplate® FML-2 grease upon reassembly.
1. Grease and assemble two (172) “O” rings to (103) sleeve.
 2. Assemble (103) sleeve into the (101) air valve body.
 3. Grease and assemble (70 and 173) “O” rings to (101) air valve body.
 4. Grease and assemble (144) “U” cup into (68) air cap.
 5. Assemble (101) air valve body to (68) air cap.
 6. Assemble four (131) screws, securing (68) air cap. NOTE: Tighten (131) screws to 20 - 30 ft lbs (27.1 - 40.7 Nm).
 7. Assemble (9) washer, (3) “O” ring, (6) washer, (7) or (7 and 8) diaphragms, (196) cushion, (5) back-up washer and (2) stopper to (14) screw. NOTE: For models with Teflon diaphragms: Item (8) Santoprene diaphragm is installed with the side marked “AIR SIDE” towards the pump center body. Install the Teflon diaphragm (7) with the side marked “FLUID SIDE” towards the (15) fluid cap.
 8. Assemble (1) rod to (14) screw.
 9. Grease and assemble two (173) “O” rings to (1) rod.
 10. Place this assembly into (68) air cap.
 11. Assemble (10) washer and (186) screw into (101) air valve body and thread into (1) rod. Clamp (14) screw in a vise, with (186) screw upward, and tighten (186) screw to 65 - 70 ft lbs (88.1 - 94.9 Nm).
 12. Remove assembly from the vise and assemble to (15) fluid cap, securing with eight (27) screws and (29) nuts. NOTE: Tighten (27) screws to 60 - 70 ft lbs (81.3 - 94.9 Nm).
 13. Grease and assemble two (11) “O” rings to two (4) flanges.
 14. Assemble two (4) flanges to (15) fluid cap, securing with six (26) screws. NOTE: Tighten (26) screws to 60 - 70 ft lbs (81.3 - 94.9 Nm).
 15. Apply Lubriplate FML-2 grease to threads of (101) air valve body. Apply Teflon tape to (107) reducing bushing and assemble to (101) air valve body.

PARTS LIST

✓ Indicates parts included in 637330-3X Service Kit. Service Kit also includes 94276 Lubriplate FML-2 grease packet.

DIAPHRAGM OPTIONS SB30X-XXX-X

Item	Description (size)	Qty	SB30X-XXX-A		SB30X-XXX-G		SB30X-XXX-T		SB30X-XXX-V	
			Part No.	[Mtl]	Part No.	[Mtl]	Part No.	[Mtl]	Part No.	[Mtl]
✓	Service Kit		637330-3A		637330-3G		637330-3T		637330-3V	
✓ 7	Diaphragm	(1)	94091-A	[SP]	94091-G	[B]	94090-T	[T]	95345	[V]
✓ 8	Diaphragm	(1)	-----	---	-----	---	94110-A	[SP]	-----	---
✓ 11	"O" Ring (1/8" x 5" o.d.)	(2)	95187	[E]	Y325-248	[B]	Y328-248	[T]	Y327-248	[V]

AIR SECTION PART OPTIONS SB30X-

Item	Description (size)	Qty	SB30A-		SB30S-	
			Part No.	[Mtl]	Part No.	[Mtl]
5	Back-up Washer	(1)	94831-1	[C]	94831-2	[SS]
68	Air Cap	(1)	94030-3	[A]	94031-4	[SS]
101	Air Valve Body	(1)	94839	[A]	94843	[SS]
107	Reducing Bushing (1-1/2 - 11-1/2 N.P.T. male x 3/4 - 14 N.P.T. female)	(1)	Y45-22-C	[I]	Y45-322-T	[SS]
181	Roll Pin (5/32" o.d. x 3/4" long)	(2)	-----	---	Y178-56-S	[SS]

FLUID CAP MATERIAL OPTIONS SB30X-XXX-X

Item	Description (size)	Qty	SB30X-XAX-X		SB30X-XCX-X		SB30X-XSX-X	
			Part No.	[Mtl]	Part No.	[Mtl]	Part No.	[Mtl]
4	Flange	(2)	94846-☆	[A]	94847-☆	[CI]	94940-☆	[SS]
15	Fluid Cap	(1)	94024	[A]	94106	[CI]	94107	[SS]

☆ For BSP thread models (SB30X-BXX-X), use "-1".

MATERIAL CODE

[A]	= Aluminum
[B]	= Nitrile
[Br]	= Brass
[Bz]	= Bronze
[C]	= Carbon Steel
[CI]	= Cast Iron
[Co]	= Copper
[D]	= Acetal
[E]	= E.P.R.
[I]	= Iron
[SP]	= Santoprene
[SS]	= Stainless Steel
[T]	= Teflon
[V]	= Viton

EXTERNAL HARDWARE OPTION SB30X-XXX-X

Item	Description (size)	Qty	SB30X-XXP-X		SB30X-XXS-X	
			Part No.	[Mtl]	Part No.	[Mtl]
26	Screw (M12 x 1.75 - 6g x 45 mm)	(6)	94412-1	[C]	94412-2	[SS]
27	Screw (M12 x 1.75 - 6g x 60 mm)	(8)	94991-1	[C]	94991	[SS]
29	Nut (M12 x 1.75 - 6g)	(8)	95053-1	[C]	95053	[SS]

COMMON PARTS

Item	Description (size)	Qty	Part No.	[Mtl]	Item	Description (size)	Qty	Part No.	[Mtl]
1	Rod	(1)	94941	[C]	70	"O" Ring (3/32" x 5/8" o.d.)	(4)	Y325-111	[B]
2	Stopper	(1)	94837	[D]	103	Sleeve	(1)	94836	[Bz]
✓ 3	"O" Ring (1/8" x 1" o.d.)	(1)	Y328-210	[T]	131	Screw (M10 x 1.5 - 6g x 30 mm)	(4)	94845	[C]
6	Washer	(1)	94942	[SS]	✓ 144	"U" Cup (3/16" x 1-3/8" o.d.)	(1)	Y186-51	[B]
9	Washer (13/16" i.d. x 2" o.d.)	(1)	Y13-12-T	[SS]	✓ 172	"O" Ring (1/16" x 1-1/4" o.d.)	(2)	Y325-24	[B]
10	Washer (0.630" i.d. x 1.750" o.d.)	(1)	93065	[SS]	✓ 173	"O" Ring (3/32" x 1" o.d.)	(3)	Y330-117	[B]
14	Screw (3/4" - 16 x 2-1/2")	(1)	Y5-131-T	[SS]	186	Screw (5/8" - 18 x 1")	(1)	Y5-105-C	[C]
19	Screw, Self-Tapping (1/4" - 20 x 1/2")	(1)	Y254-178-Z	[C]	✓ 196	Cushion	(1)	94631	[SP]
43	Ground Lug	(1)	93004	[Co]	201	Muffler	(1)	20312-1	[Br]

PARTS LIST

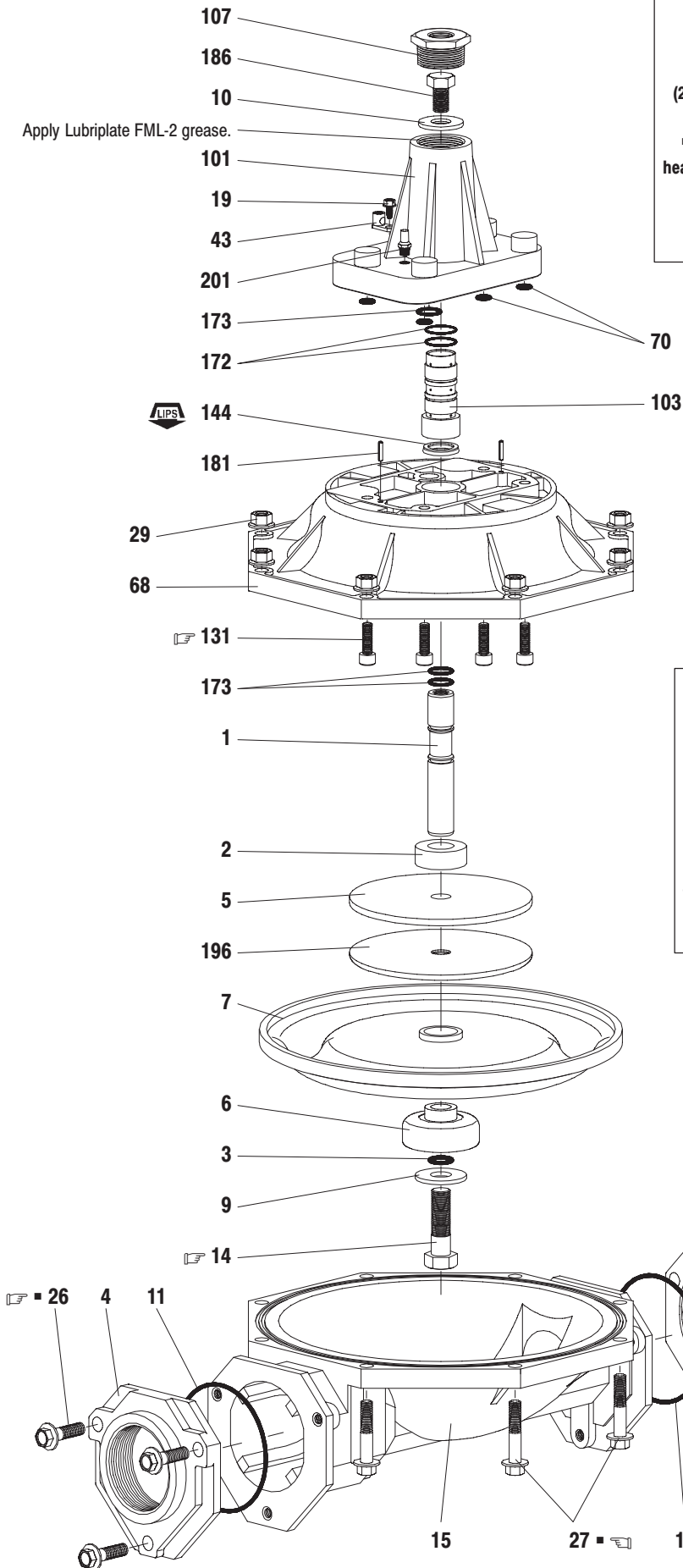

TORQUE REQUIREMENTS

NOTE: DO NOT OVERTIGHTEN FASTENERS

- (14) Diaphragm screw, 65 - 70 ft lbs (88.1 - 94.9 Nm).
- (26 and 27) Fluid caps / flange screw, 60 - 70 ft lbs (81.3 - 94.9 Nm).
- (131) Screw, 20 - 30 ft lbs (27.1 - 40.7 Nm).

▪ Apply anti-seize compound to threads and bolt and nut flange heads which contact pump case when using stainless steel fasteners.

LUBRICATION / SEALANTS

☆ Apply Lubriplate FML-2 grease to all "O" rings, "U" Cups & mating parts.

◇ Lubriplate FML-2 is a white food grade petroleum grease.

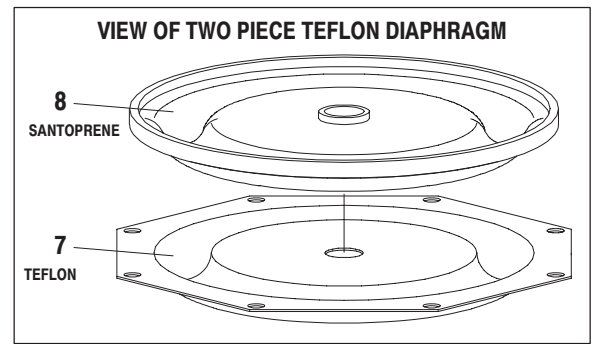
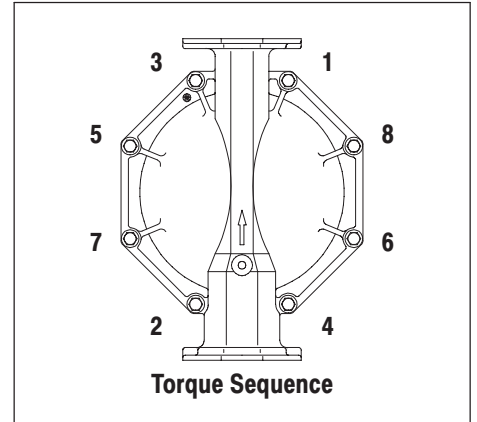

COLOR CODE	
MATERIAL	DIAPHRAGM
NITRILE	BLACK
SANTOPRENE	TAN
SANTOPRENE (Back-Up)	GREEN
TEFLON	WHITE
VITON	YELLOW (-)
	(-) Dash

Figure 3

TYPICAL CROSS SECTION

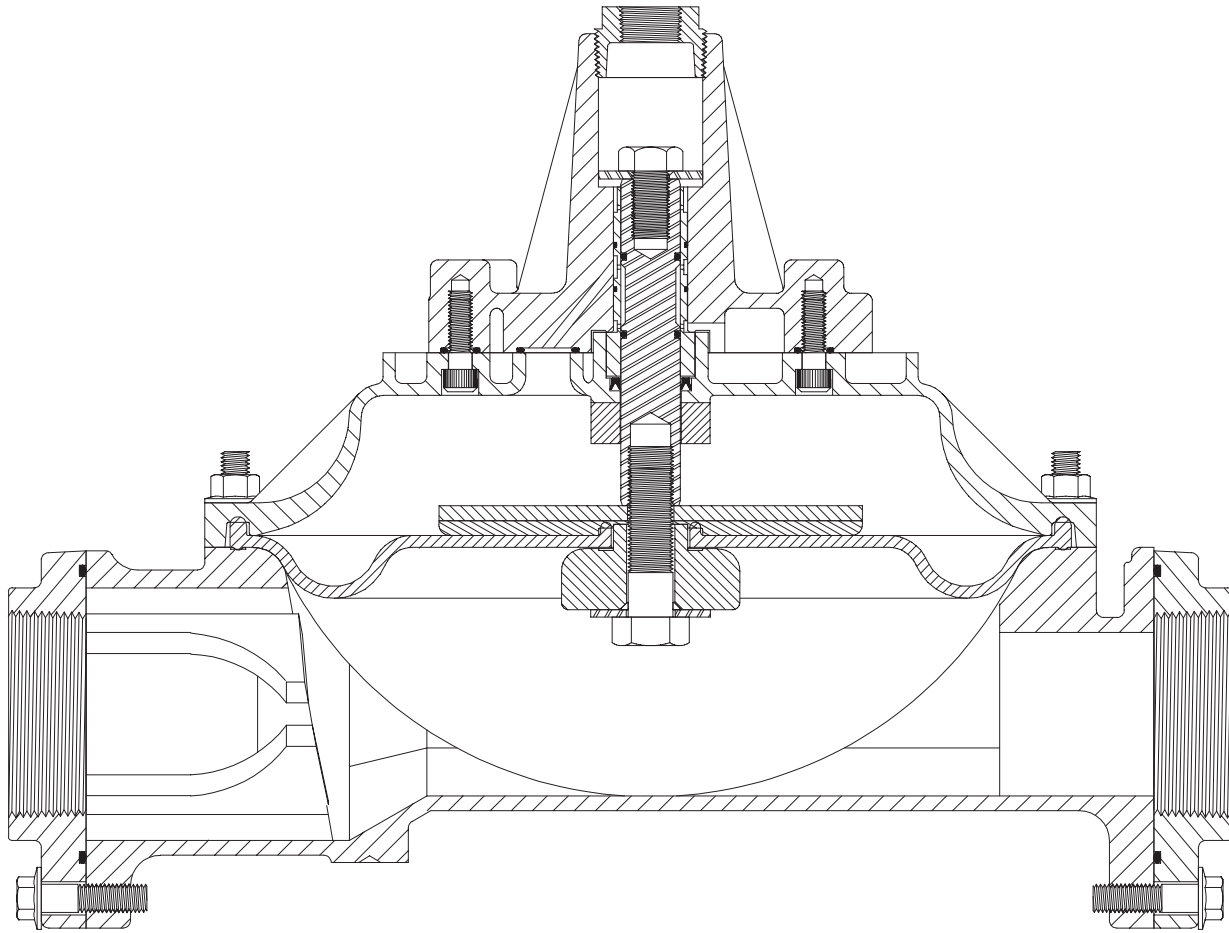

Figure 4

TROUBLE SHOOTING

No dampening effect or erratic performance.

- Check for diaphragm rupture.
- Check for blocked or restricted outlet hoses.
- Check the air supply. Make certain the air pressure to the Shock Blocker is equal to the fluid pressure.

Constant air leakage:

- from exhaust port.
 - Check for damaged (172 and 173) "O" rings.
- from air cap.
 - Check the tightness of (27) screws.

Air bubbles in product discharge.

- Check connections of the pump's suction plumbing.
- Check tightness of (14) diaphragm screw.

Fluid leakage:

- from exhaust port.
 - Check for diaphragm rupture.
- from flange.
 - Check for damaged (11) "O" ring.
 - Check the tightness of (26) screws.
- from fluid cap.
 - Check air pressure to the valve block (relieve fluid pressure).
 - Check the tightness of (27) screws.
 - Check for cracks. Discontinue use.

DIMENSIONAL DATA

(Dimensions shown are for reference only, they are displayed in inches and millimeters (mm)).

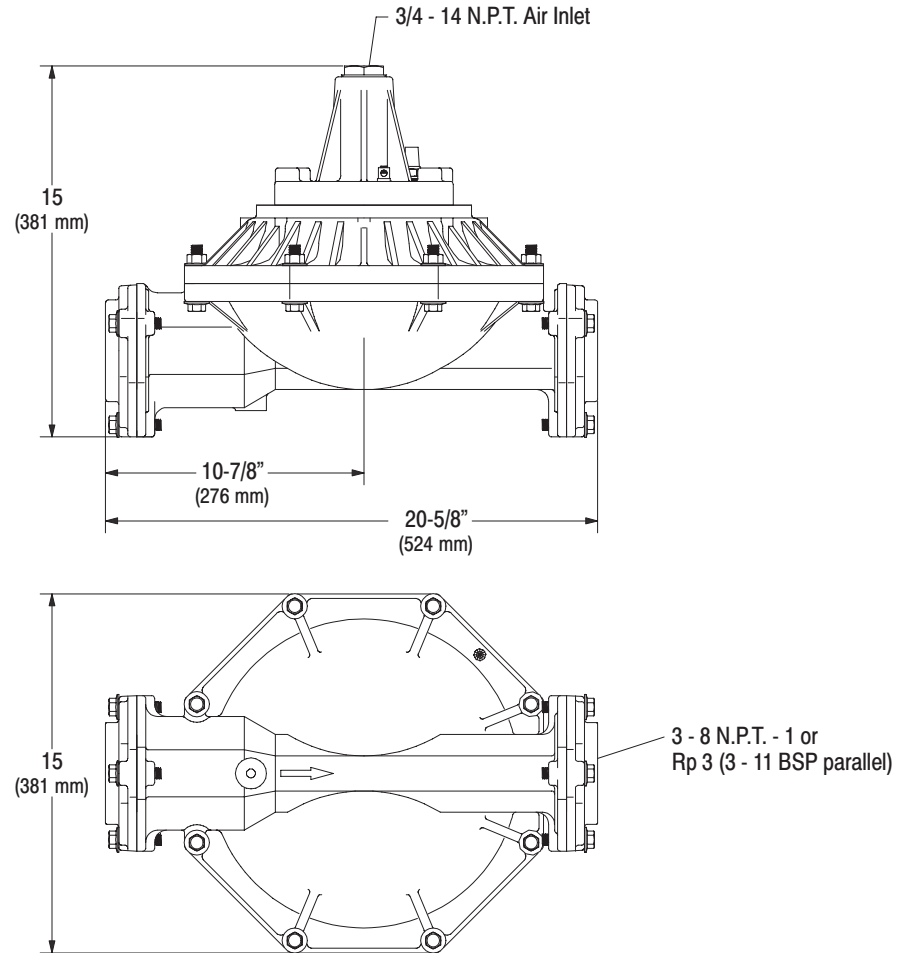

Figure 5

