

SALES & ENGINEERING DATA

RATIO SERIES: **10:1**

FLUID P.S.I. RANGE: **300 - 1200**

613112-XXF-C TWO-BALL PUMP

RELEASED: 7-26-02
REVISED: S-1010

DIMENSIONAL DATA

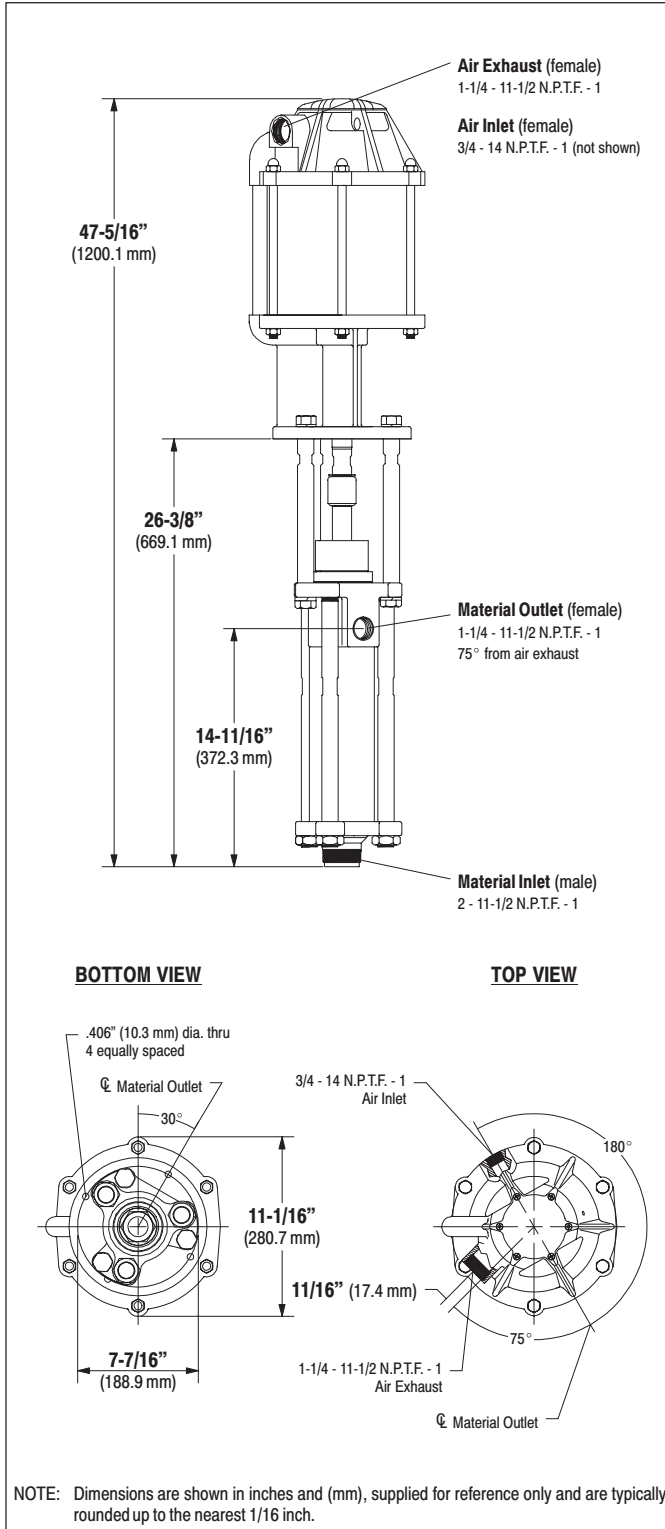

SPECIFICATIONS

CONSTRUCTION

Model Series (refer to option chart)	613112-XXF-C
Pump Type	Air Operated, Two-Ball, Double Acting Pump
Ratio	10:1
Air Motor	66523-B
Motor Repair Kit	66614
Motor Diameter	8" (203.2 mm)
Stroke	6" (152.4 mm)
Air Inlet (female)	3/4 - 14 N.P.T.F. - 1
Air Exhaust (female)	1-1/4 - 11-1/2 N.P.T.F. - 1
Lower Pump End Series	66942-XXF
Lower Pump Repair Kit	637211-X63
Packing Options:	

C	- UHMW-PE
K	- Carbon-Graphite Filled Teflon with Nitrile Energizer
L	- Mineral Filled Teflon
P	- UHMW-PE / Mineral Filled Teflon staggered upper • UHMW-PE lower
R	- Mineral Filled Teflon / UHMW-PE staggered upper • Mineral Filled Teflon lower

Material Inlet (male)	2 - 11-1/2 N.P.T.F. - 1
Material Outlet (female)	1-1/4 - 11-1/2 N.P.T.F. - 1

MATERIALS OF CONSTRUCTION

Outlet Body	316 Stainless Steel
Cylinder	304 Stainless Steel, Chrome plated
Plunger	321 Stainless Steel, Chrome plated
Upper Ball	316 Stainless Steel
Upper Seat	
613112-X3F-C, 613112-X6F-C	316 Stainless Steel
613112-XCF-C, 613112-XDF-C	Tungsten Carbide
Lower Ball	316 Stainless Steel
Lower Seat	
613112-X3F-C, 613112-X6F-C	316 Stainless Steel
613112-XCF-C, 613112-XDF-C	Tungsten Carbide
Inlet Body	316 Stainless Steel
Weight	102 lbs (46.3 kgs)

PERFORMANCE

Air Inlet Pressure Range	30 - 120 p.s.i. (2.1 - 8.3 bar)
Fluid Pressure Range	300 - 1200 p.s.i. (20.7 - 82.8 bar)
Maximum Rec'd Cycles / Minute	70
Displacement In³ Per Cycle	59.8
Volume / Cycle	33.1 oz. (979.6 ml)
Cycles Per Gallon	3.9
Flow @ 70 Cycles / Minute	18.1 g.p.m. (68.6 l.p.m.)
Noise Level @ 60 p.s.i. - 40 c.p.m.	89.8 db(A) ^①

① Tested with 92460 Muffler installed. The pump sound pressure level has been updated to an Equivalent Continuous Sound Level (L_{Aeq}) to meet the intent of ANSI S1.13-1971, CAGI-PNEUROP S5.1 using four microphone locations.

ACCESSORIES:

- 66542 Wall Mount Bracket
- 67187-1 Mounting Post
- 92460 Silencer



PERFORMANCE CURVES

