

# OPERATOR'S MANUAL

# NP623R01-1M

## INCLUDING: OPERATION, INSTALLATION & MAINTENANCE

INCLUDE MANUALS: BASIC PUMP (AS SPECIFIED), 651616-X TWO POST LIFT / RAM (PN 97999-613), 65940-X AIR MANIFOLD (PN 97999-131) & S-636 GENERAL INFORMATION (PN 97999-636).

RELEASED: 6-1-00

REVISED: 5-1-02

(REV. B)

**6" AIR MOTOR  
RATIO (AS SPECIFIED)  
6" STROKE**

## EXTRUSION SYSTEM



**READ THIS MANUAL CAREFULLY BEFORE INSTALLING,  
OPERATING OR SERVICING THIS EQUIPMENT.**

It is the responsibility of the employer to place this information in the hands of the operator. Keep for future reference.

### SERVICE KITS

29960 for repair of 27344-000 heavy duty regulator.  
104020 for repair of 25341-010 heavy duty filter.  
104023 for repair of 26341-010 heavy duty lubricator.

### GENERAL DESCRIPTION

By delivering a smooth, continuous bead of the proper size, an ARO system helps the operator maintain both production rate and produce high quality standards. Maintained quality standards assures that the material benefits are realized. To further maximize operator production time, the ARO system has a built-in lift / ram feature for quick and easy drum changeover and easy lifting of pump assembly from the container.

ARO systems are totally enclosed, sealing the material in the system from air and moisture, preventing premature cure-out of the material. This allows for either continuous or intermittent use of the system and allows the need for daily system clean-up.

### MODEL DESCRIPTION CHART

NP 6 23 R 01 - 1 M	
<b>AIR MOTOR SIZE</b>	6 - 6"
<b>PUMP NUMBER</b>	23 - 23:1 Chop-Check
<b>MOUNT STYLE</b>	R - Ram
<b>SEQUENCE NUMBER</b>	01
<b>OPTION</b>	1
<b>O.E.M.</b>	M

NP623R01-1M EXTRUSION SYSTEM

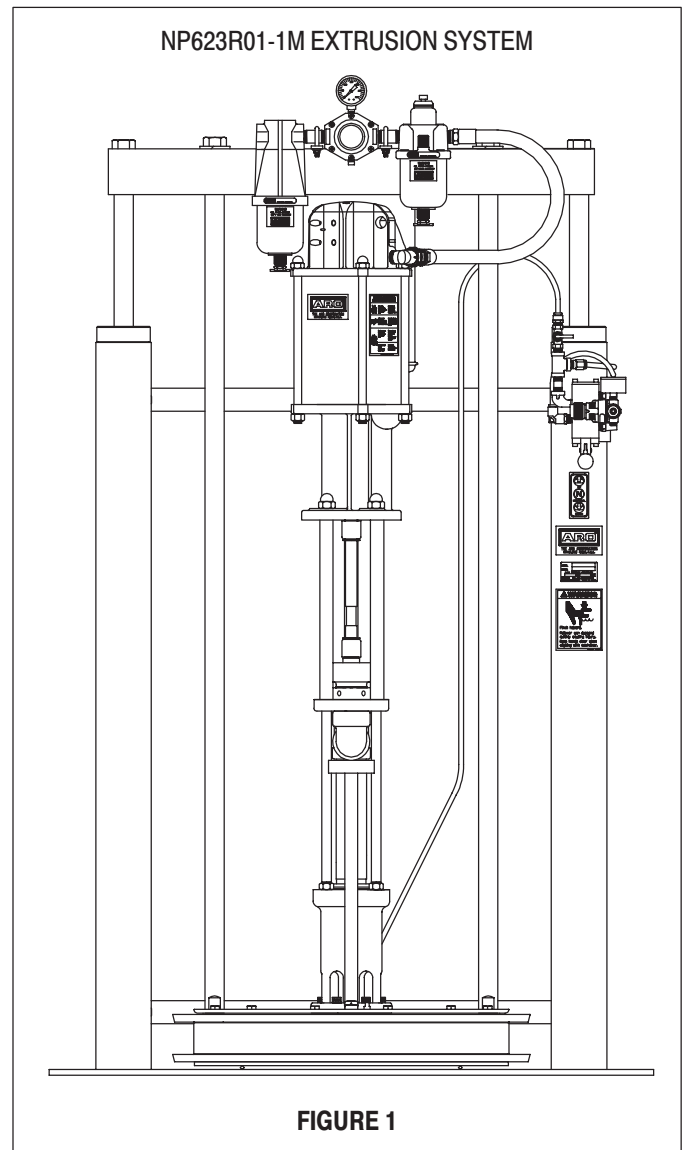

## INSTALLATION

The NP623R01-1M Extrusion System comes completely assembled. Remove the unit from the crate and place on a level surface. Install material hose and dispensing device as required.

When the following instructions are observed, heavy paste materials

can be pumped directly from their original drum without air inclusion or excessive waste. The follower plate creates an air tight seal as well as clean-wiping action in its progressive downward movement into the drum.

## OPERATING INSTRUCTIONS

### OPERATING INSTRUCTIONS / INITIAL SETUP PROCEDURE

#### **⚠ WARNING** STAND CLEAR. When raising or lowering the lift.

Read the warning on page 2 of 651616-X Two Post Lift / Ram Operator's Manual.

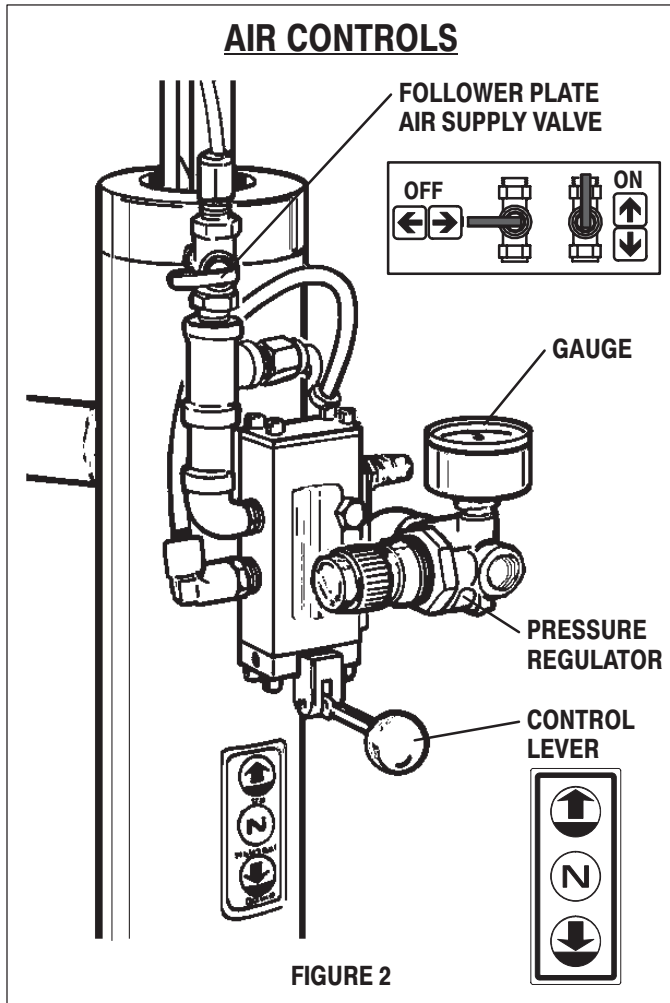

#### TO RAISE LIFT, (THE FIRST TIME):

1. Take note of the pump / drum clearance above. Be certain the lift / ram is clear of any objects above. Also refer to "Operating and Safety Precautions" found on page 2 of 651616-X Two Post Lift / Ram Operator's Manual.
2. Connect the air supply (150 p.s.i. max.) to the air inlet. Adjust air pressure on lift / ram pressure regulator (turn knob clockwise) to 20 p.s.i. (1.4 bar).
3. Shift the control valve lever to the "up" position.
4. Raise the lift / ram high enough to clear the height of the drum. Stop the lift upward travel by moving the control valve lever to the "neutral" (center) position.

#### REFER TO PAGE 3:

1. Once the lift / ram assembly and pump are in the "up" position, place and center an opened 5 or 55 gallon drum of material on the lift / ram base.
2. Lubricate the lower follower wiper plate seal with grease. NOTE: Make certain the grease is compatible with the material being dispensed. This ensures a smooth fit into the drum, as well as prevents curing type compounds from bonding to the seal.
3. Check the vent plug on the follower plate to be sure it easily threads in and out. It is recommended to lubricate the threads of the plug to help prevent possible set up of the compound at this point (see 651616-X Operator's Manual).

#### TO LOWER LIFT:

**⚠ WARNING** PINCH HAZARD. Follower can descend quickly, causing injury. Keep hands clear when aligning with container. Read the warning on page 2 of 651616-X Two Post Lift / Ram Operator's Manual.

**NOTE:** Be certain the follower plate vent plug has been removed so that the air trapped between the follower and the material is allowed to escape from this vent. Captured air between the follower plate and drum will escape.

**NOTE:** The lift / ram may hesitate momentarily before starting downward, the air pressure inside the post air chamber must decrease before it will begin to descend.

1. Shift the control valve lever to the "down" position and proceed to lower the pump.
2. Replace the vent plug once the material begins to ooze from the vent opening.
3. The unit is now ready for operation. Adjust the air pressure on the pump filter / regulator (turn the pump regulator knob clockwise) until the pump begins to cycle.
4. Trigger the gun to prime the pump with material.

#### TO RAISE LIFT, (NORMAL OPERATION):

1. Adjust the follower plate air valve pressure up to approximately 8 p.s.i.g. (.55 bar). DO NOT OVERPRESSURIZE THE DRUM to avoid damage. NOTE: Air from this valve will only pass when the control lever is in the "up" position.
2. Shift the control valve lever to the "up" position.
3. Raise the lift / ram high enough to clear the height of the drum. Stop the lift upward travel by moving the control valve lever to the "neutral" (center) position.

#### TO CHANGE DRUM:

**NOTE:** The control lever should be in the "neutral" position.

1. Unscrew thumb screw and remove old drum.
2. Place and center a new drum into position. Remove cover. Tighten thumb screw.

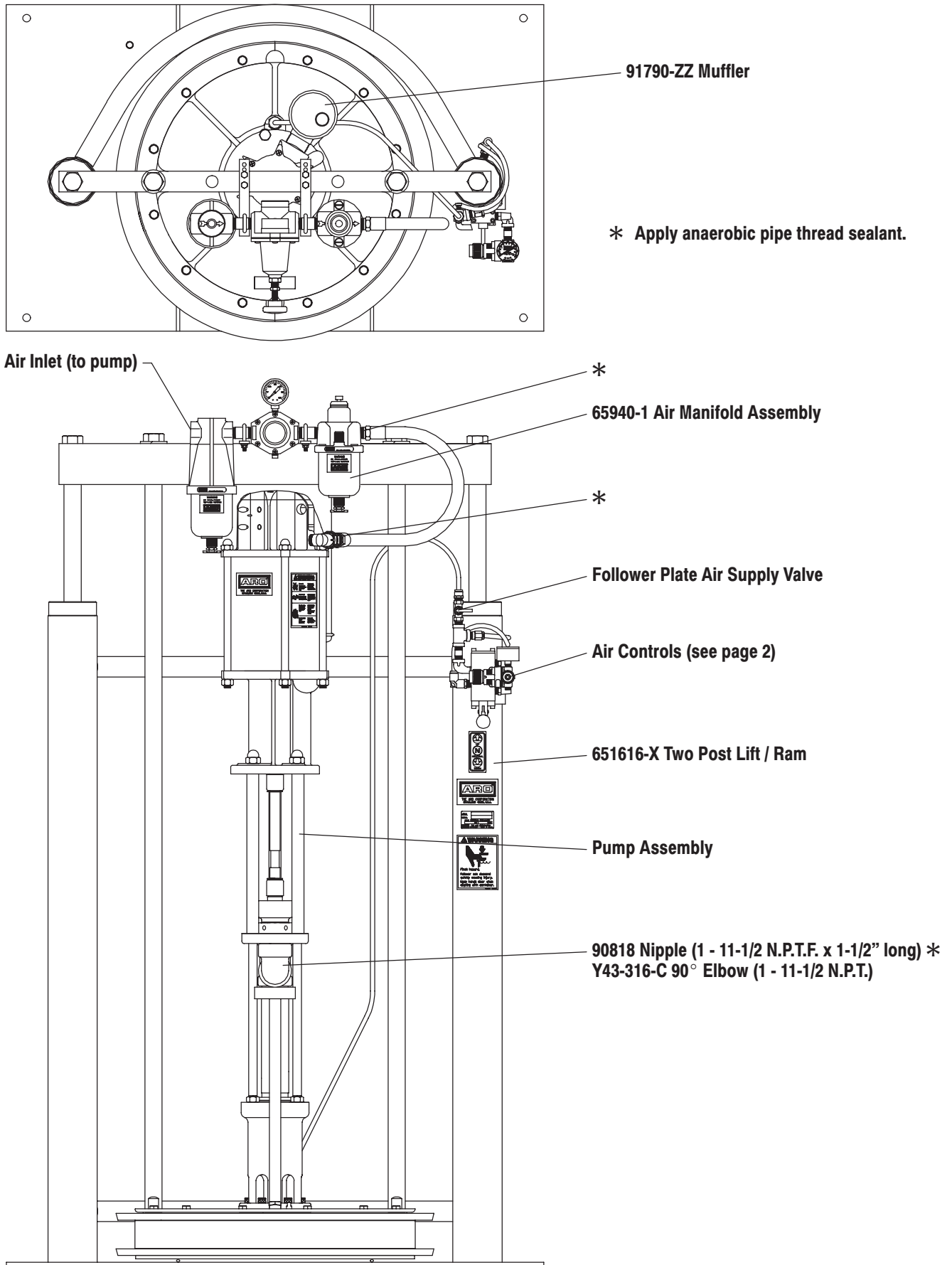

FIGURE 3

