

OPERATOR'S MANUAL

INCLUDING: SERVICE KIT, TROUBLESHOOTING, PARTS LIST, DISASSEMBLY & REASSEMBLY

67317-X

67318-X

TWO-BALL STYLE LOWER PUMP ENDS STAINLESS STEEL

RELEASED: 3-6-03
REVISED: 1-12-06
(REV. F)

ALSO COVERS 637379-X SERVICE KITS



**READ THIS MANUAL CAREFULLY BEFORE INSTALLING,
OPERATING OR SERVICING THIS EQUIPMENT.**

It is the responsibility of the employer to place this information in the hands of the operator. Keep for future reference.

SERVICE KITS

- Use only genuine ARO® replacement parts to assure compatible pressure rating and longest service life.
- 637379-X31 for general repair of 6731X-X31 lower pump ends.

GENERAL DESCRIPTION

⚠ WARNING DO NOT EXCEED MAXIMUM OPERATING PRESSURE AS INDICATED ON PUMP MODEL PLATE.

⚠ WARNING REFER TO GENERAL INFORMATION SHEET FOR ADDITIONAL SAFETY PRECAUTIONS AND IMPORTANT INFORMATION.

- This manual only covers the lower pump section, it is one of four documents which support an ARO pump. Replacement copies of these forms are available upon request.
 - NM2202B-X Pump Model Operator's Manual.
 - General Information for Air Operated or Hydraulically Operated Pumps.
 - Lower Pump End Operator's Manual.
 - Air or Hydraulic Motor Operator's Manual.
- The two-ball design provides for easy priming of the lower foot valve. The double acting feature is standard in all ARO industrial pumps, material is delivered to the pump discharge outlet on both the up and down stroke.

MAINTENANCE

The air / hydraulic motor is completely separate from the lower pump end. This helps to keep the motor from being contaminated by the material being pumped. Periodically, flush entire pump system with a lubricant that is compatible with the material being pumped.

Provide a clean work surface to protect sensitive internal moving parts from contamination from dirt and foreign matter during disassembly and reassembly.

Before reassembling, lubricate parts as required. When assembling "O" rings, or parts adjacent to "O" rings, exercise care to prevent damage to "O" rings and "O" ring groove surface.

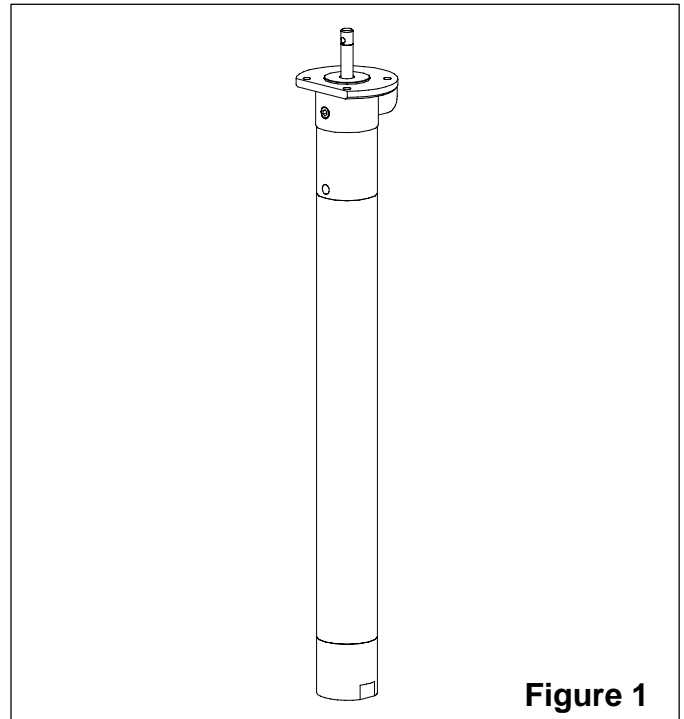

Figure 1

LOWER PUMP END DESCRIPTION CHART

6731 X - X 3 1	
CONTAINER SUITABILITY	
7 - 55 Gallon	
8 - Universal (Stub)	
PACKING MATERIAL	
7 - Teflon (upper and lower)	
B - UHMW-PE (upper) / Teflon (lower)	
C - UHMW-PE (upper and lower)	
J - Polyurethane (upper) / UHMW-PE (lower)	
SPRING ARRANGEMENT	
3 - No Spring	
PLUNGER TYPE	
1 - Standard (300 Series Stainless Steel)	
SERVICE KIT SELECTION	6731X - X 3 1
EXAMPLE: Lower Pump End # 67317-C31	637379 - [X] 31
Service Kit # 637379-C31	Packing []

PARTS LIST

Item	Description (size)	Qty	Part No.	[Mtl]
✓ 1	"O" Ring (1/8" x 11/16" o.d.)	(1)	Y327-205	[V]
2	Pipe Plug (1/8 - 27 N.P.T.F. x 0.27")	(1)	Y17-50	[C]
3	Outlet Body	(1)	95705	[SS]
4	Ground Screw (#10 - 32 x 1/4")	(1)	93005	[C]
6	Inner Tube	(1)	95712	[SS]
7	Rod	(1)	96063	[C]
8	Dowel Pin (3/16" o.d. x 7/8")	(1)	95803	[C]
9	Retainer	(1)	95804	[SH]
10	Washer	(2)	95234-1	[PPS]
✓ 11	Rod Seal models 6731X-731	(1)	95574-2	[T]
	models 6731X-B31 and -C31	(1)	95574-1	[UH]
	models 6731X-J31	(1)	95235	[U]
12	Retaining Ring (0.575" i.d.)	(1)	95711	[SH]
13	Rod models 6731Z-X (18.000" long)	(1)	95710	[SS]
	models 6731B-X (5.500" long)	(1)	95713	[SS]

MATERIAL CODE

[C] = Carbon Steel	[T] = Teflon
[PPS] = Polyphenylene Sulfide	[U] = Polyurethane
[SH] = Hardened Stainless Steel	[UH] = UHMW-PE
[SS] = Stainless Steel	[V] = Viton

LOWER PUMP DISASSEMBLY

NOTE: All threads are right hand.

- Clamp (3) outlet body horizontally in a vise. Using a strap type wrench to hold (19) suction tube, unthread and remove (23 or 24) foot valve seat.
- Remove (22) dowel pin, releasing (21) ball.
- Using a strap type wrench, unthread and remove (19) suction tube.
- Remove (13) rod and components from (19) suction tube.
- Using a 1-1/2" wrench, unthread and remove (18) inner check seat, releasing (17) ball, (16) washer and (15) cup.
- Slide (12) retaining ring, (10) washers, (11) rod seal and (9) retainer down (13) rod, allowing removal of (8) dowel pin.
- Remove (7) rod, (9) retainer, two (10) washers, (11) rod seal and (12) retaining ring from (13) rod.
- Remove (1) "O" ring from (3) outlet body.
- DO NOT remove (6) inner tube unless damage is evident. To remove, clamp (3) outlet body in a vise and unthread (6) inner tube using a strap type wrench.

LOWER PUMP REASSEMBLY

NOTE: Refer to the illustration (figure 2, page 3) for lip seal direction.
NOTE: All threads are right hand. Thoroughly clean and lubricate all seals and bores with Wet-Sol "Plus" upon assembly.

- Assemble (15) cup, (16) washer and (17) ball to (14) cup follower, securing with (18) inner check seat. NOTE: Tighten (18) inner check seat to 60 - 70 ft lbs (81.3 - 94.9 Nm).
- Assemble (14) cup follower and components to (13) rod. NOTE: Tighten (14) cup follower to 60 - 70 ft lbs (81.3 - 94.9 Nm).
- Slide (12) retaining ring, (10) washer, (11) rod seal (lips down), (10)

Item	Description (size)	Qty	Part No.	[Mtl]
14	Cup Follower	(1)	90601	[SS]
✓ 15	Cup models 6731X-731 and -B31	(1)	73919	[T]
	models 6731X-C31 and -J31	(1)	92867-1	[UH]
16	Washer	(1)	90610	[SS]
17	Ball (1.000" dia.)	(1)	90948	[SS]
18	Inner Check Seat	(1)	96144	[SS]
19	Suction Tube models 6731Z-X	(1)	95706	[SS]
	models 6731B-X	(1)	95714	[SS]
21	Ball (1.1875" dia.)	(1)	90949	[SS]
22	Dowel Pin (0.25" o.d. x 1.828")	(1)	90620	[SS]
23	Foot Valve Seat (models 6731Z-X only)	(1)	95977	[SS]
24	Foot Valve Seat (models 6731B-X only)	(1)	96015	[SS]
✓	Darina "EP" 2 Grease Packet	(1)	94833	
✓	Items included in Service Kit		637379-X31	

washer and (9) retainer onto top end of (13) rod, past the retaining ring groove.

- Assemble (7) rod to (13) rod, securing with (8) dowel pin.
- Slide (9) retainer, (10) washer, (11) rod seal, (10) washer and (12) retaining ring up, securing (8) dowel pin.
- Clamp (3) outlet body horizontally in a vise.
- Apply Teflon® tape to 1-7/16" threads of (3) outlet body and assemble (6) inner tube to (3) outlet body. NOTE: Tighten (6) inner tube to 120 in. lbs (13.6 Nm) minimum.
- Assemble (1) "O" ring into (3) outlet body.
- Assemble (7) rod and components into (6) inner tube and (3) outlet body.
- Assemble (21) ball to (23 or 24) foot valve seat, securing with (22) dowel pin.
- Apply Teflon tape to threads of (23 or 24) foot valve seat and assemble (23 or 24) foot valve seat and components to (19) suction tube. NOTE: Tighten (23 or 24) foot valve seat to 60 - 70 ft lbs (81.3 - 94.9 Nm).
- Apply Teflon tape to threads of (3) outlet body and assemble (19) suction tube to (3) outlet body. NOTE: Tighten (19) suction tube to 60 - 70 ft lbs (81.3 - 94.9 Nm).

TROUBLE SHOOTING

- No material at outlet (pump continually cycles).** Check material supply, disconnect or shut off the air supply and replenish the material, reconnect.
- Material on one stroke only (fast downstroke).** The (21) lower ball may not be seating in the (23 or 24) foot valve seat. Remove the (21) ball from the foot valve seat, clean and inspect the ball and seat area. If the ball or seat is damaged, replace.
- Material on one stroke only (fast upstroke).** The (17) upper ball may not be seating in the (18) inner check seat. Remove the (17) ball from the (18) check seat, clean and inspect. If the (17) ball is damaged, replace. Check for worn or damaged packings and seals. Replace the packings and seals as necessary.

PARTS LIST

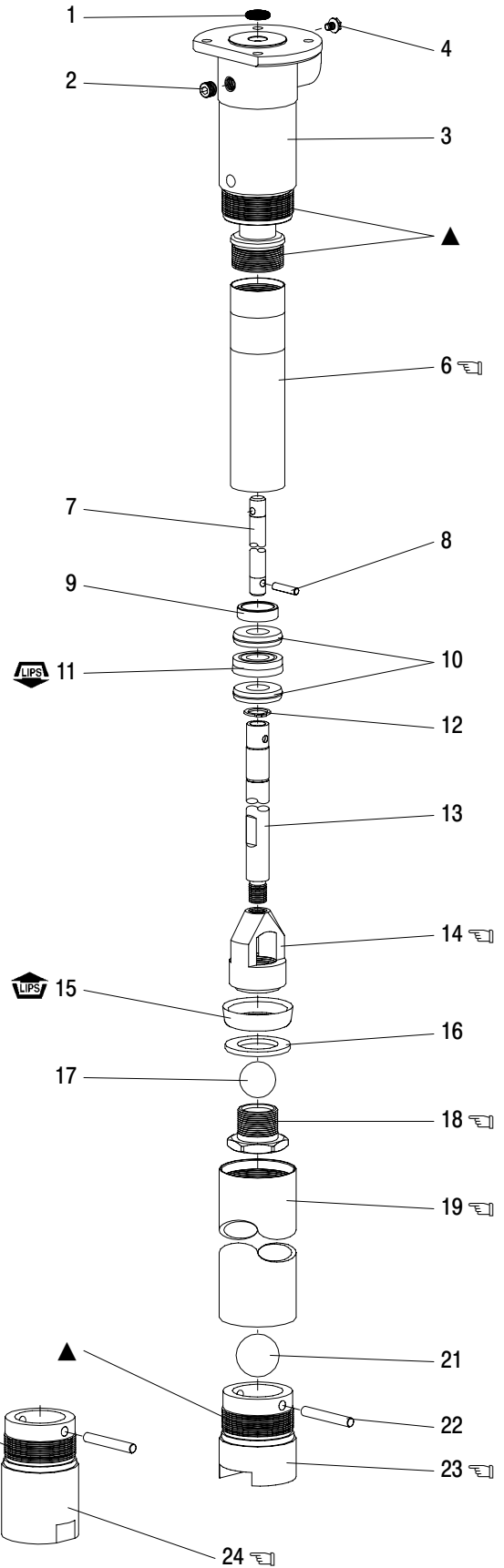
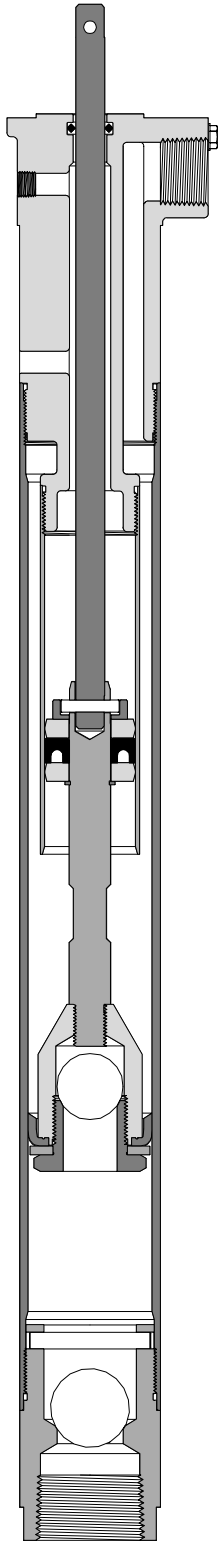

TORQUE REQUIREMENTS
NOTE: DO NOT OVERTIGHTEN COMPONENTS.
(6) 120 in. lbs (13.6 Nm) minimum.
(14), (18), (19), (23), (24) 60 - 70 ft lbs (81.3 - 94.9 Nm).

LUBRICATION / SEALANTS
 Lubricate all seals and threads with Wet-Sol Plus.
 ▲ Apply Teflon tape to threads.

Figure 2

