

# OPERATOR'S MANUAL

INCLUDING: OPERATION, INSTALLATION & MAINTENANCE

# 6544X-X

# 6546X-X

RELEASED: 2-26-82

REVISED: 10-10-01

(REV. S)

## 4-1/4" AIR MOTORS

**6544X-X**  
**4" STROKE**

**6546X-X**  
**6" STROKE**



**READ THIS MANUAL CAREFULLY BEFORE INSTALLING,  
OPERATING OR SERVICING THIS EQUIPMENT.**

It is the responsibility of the employer to place this information in the hands of the operator. Keep for future reference.

### THIS MANUAL COVERS THE FOLLOWING MODELS

MODEL			
65440	65442-B	65444-2-B	65465-B
65441-B	65444-B	65445-B	65466

ALSO COVERS OBSOLETE AND CANCELLED MODELS: 61777, 65420-1, 65443-B, 65443-2-B, 65444-1B, 65462 AND 65465-1-B.

### SERVICE KITS

61268 for general repair of all 4-1/4" air motors.

### GENERAL DESCRIPTION

The 4-1/4" air motor is a general purpose power unit and is used with many 2-ball, 4-ball and chop check pumps. It utilizes tie rod type construction for easy breakdown and it connects to the various lower ends via tie rods for easy operation. Consult pump model operator's manual for specific instructions. It is recommended that a muffler be connected to the exhaust port to reduce noise to acceptable OSHA standards.

Filtered and oiled air will allow the air motor to operate more efficiently and yield a longer life to operating parts and mechanisms. A filter capable of filtering particles larger than 50 microns should be used with an oiler. Keep the oiler supplied with a good grade of S.A.E. no. 90W non-detergent gear oil, set at a rate not to exceed 1 or 2 drops per minute.

### NOTICE

**DO NOT OPERATE AIR MOTOR ABOVE RECOMMENDED AIR PRESSURE OF 150 P.S.I. (10.3 BAR) OR 75 CYCLES PER MINUTE. Air motor may be rated differently in the next assembly. Check pump model plate.**

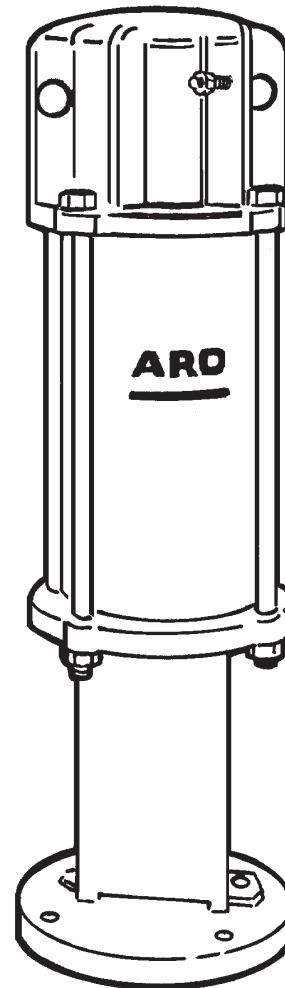

# AIR MOTOR PARTS LIST

✓ PARTS SO MARKED ARE INCLUDED IN 61268 SERVICE KIT.

REF.	DESCRIPTION (SIZE IN INCHES)	QTY	PART NO.
<input type="checkbox"/> 1	Screw (#8 - 32 x 7/8") (not shown)	4	Y136-90-S
<input type="checkbox"/> 2	Deflector (not shown)	1	90409
<input type="checkbox"/> 3	Screw (#10 - 24 x 1/2")	6	95956827
✓ <input type="checkbox"/> 4	Screw (#8 - 32 x 3/4")	4	Y19-89-S
✓ <input type="checkbox"/> 5	Washer	4	90084
<input type="checkbox"/> 6	Screw (1/4" - 28 x 3/4")	2	Y119-49-C
<input type="checkbox"/> 7	Lock Washer (1/4" i.d.)	2	Y14-416
<input type="checkbox"/> 8	Air Motor Cap	1	90078
<input type="checkbox"/> 9	Valve Guide	1	90093
✓ <input type="checkbox"/> 10	Gasket	1	90083-1
✓ <input type="checkbox"/> 11	Insert	1	90097
● <input type="checkbox"/> 12	Valve Plate and Pin Assembly	1	65028
<input type="checkbox"/> 12a	Roll Pin (3/32" o.d. x 3/4" long)	2	Y178-26-S
<input type="checkbox"/> 13	Insert Spring Assembly	1	65032
✓ <input type="checkbox"/> 14	Valve Insert	1	90796
✓ <input type="checkbox"/> 15	Gasket	1	90091
✓ <input type="checkbox"/> 16	"O" Ring (1/16" x 1 - 3/8" o.d.)	2	Y325-26
✓ <input type="checkbox"/> 17	Washer	1	91344
✓ <input type="checkbox"/> 18	"O" Ring (1/16" x 3/4" o.d.)	2	Y325-16
<input type="checkbox"/> 19	Head Assembly	1	65889
✓ <input type="checkbox"/> 20	"U" Cup (3/16" x 1 - 3/8" o.d.)	1	Y186-51
✓ <input type="checkbox"/> 21	"O" Ring (1/8" x 4 - 1/4" o.d.)	2	Y325-242
✓ <input type="checkbox"/> 22	Screw (#8 - 32 x 3/8")	4	Y136-85-S
<input type="checkbox"/> 24	Piston Assembly	1	61851

REF.	DESCRIPTION (SIZE IN INCHES)	QTY	PART NO.
<input type="checkbox"/> 27	Rod Assembly	See chart, page 4	
<input type="checkbox"/> 28	Cylinder	See chart, page 4	
<input type="checkbox"/> 29	Tube	See chart, page 4	
<input type="checkbox"/> 30	Base and Bearing Assembly	See chart, page 4	
✓ <input type="checkbox"/> 31	Valve Piston	1	92394
✓ <input type="checkbox"/> 32	Washer	1	90105
<input type="checkbox"/> 33	Gland	1	91006
✓ <input type="checkbox"/> 34	Seal	1	91007
✓ <input type="checkbox"/> 35	"O" Ring (.103" x 1.255" o.d.)	1	91207
<input type="checkbox"/> 36	Extension Rod	1	90080
✓ <input type="checkbox"/> 38	Adapter	1	92393
<input type="checkbox"/> 39	Gland	1	90114
✓ <input type="checkbox"/> 40	Washer	1	91345
✓ <input type="checkbox"/> 41	"O" Ring (1/16" x 7/16" o.d.)	1	Y325-11
<input type="checkbox"/> 42	Bolt	See chart, page 4	
<input type="checkbox"/> 43	Snap Ring	See chart, page 4	
<input type="checkbox"/> 44	Washer	See chart, page 4	
<input type="checkbox"/> 45	"U" Cup	See chart, page 4	
<input type="checkbox"/> 46	Washer	See chart, page 4	
<input type="checkbox"/> 47	Nut	See chart, page 4	
<input type="checkbox"/> 48	Piston Rod	See chart, page 4	
<input type="checkbox"/> 49	"O" Ring	See chart, page 4	
<input type="checkbox"/> 50	Ground Lug	1	93006
<input type="checkbox"/> 51	Ground Label (not shown)	1	93007

- "Smart Parts", Keep these items on hand in addition to the service kits for fast repair and reduction of downtime.
- Includes item (12a) roll pin (qty 2).

## DISASSEMBLY OF AIR MOTOR

**NOTE: ALL THREADS ARE RIGHT HAND.**

1. Place motor in up stroke position. This can be accomplished by pushing (48) rod toward the top of the air motor.
2. Remove four (1) screws from (2) deflector.
3. Remove (2) deflector.
4. Remove six (3) screws from (8) air motor cap.
5. Remove (8) air motor cap and (10) gasket.

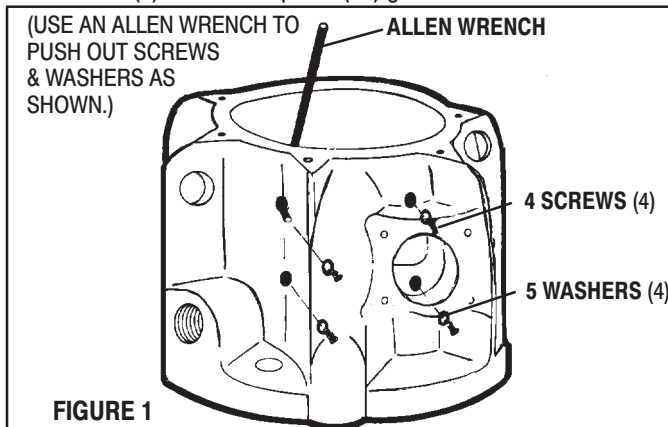

6. Loosen four (4) screws (which hold (12) valve plate and (9) valve guide) until (9) valve guide can be removed by pulling upward (see figure 8).

7. Remove four (4) screws and four (5) washers from (19) head assembly by pressing outward with a small allen wrench, as illustrated in figure 1.
8. With the aid of a screwdriver, unhook the legs of (13) insert spring assembly from the bottom of (12) valve plate.
9. Remove (12) valve plate and (13) insert spring assembly from (19) head by pulling upward. If (12) valve plate is stuck, tap the top edge lightly with a soft face mallet. **Do not tap with anything metallic.**
10. Remove both (11 and 14) inserts and (13) insert spring assembly from (12) valve plate.
11. Remove (15) gasket from (19) head assembly.
12. Remove two (6) screws and two (7) lock washers from (33) gland in (19) head assembly.
13. With fingers, pull (31) valve piston upward until (33) gland has pulled out of its chamber.
14. Remove (33) gland by sliding it up over (31) valve piston.
15. Remove (34) seal and (35) "O" ring from (33) gland (see figure 7).
16. Disassemble (31) valve piston from (38) adapter as shown in figure 3.
17. Pull (38) adapter upward until assembly is taut and grasp (36) extension rod with fingers, as shown in figure 8. Grasp (36) extension rod below (38) adapter. Now push (38) adapter down on (36) extension rod and remove (32) washer from (36) extension rod. Now remove (38) adapter.
18. Remove (17) washer and (20) "U" cup from (38) adapter.
19. Remove four (47) nuts from four (42) bolts.
20. Remove four (42) bolts.

# AIR MOTOR HEAD

PART NUMBERS LISTED BELOW AND ON PARTS LIST (OPPOSITE PAGE) ARE TYPICAL.

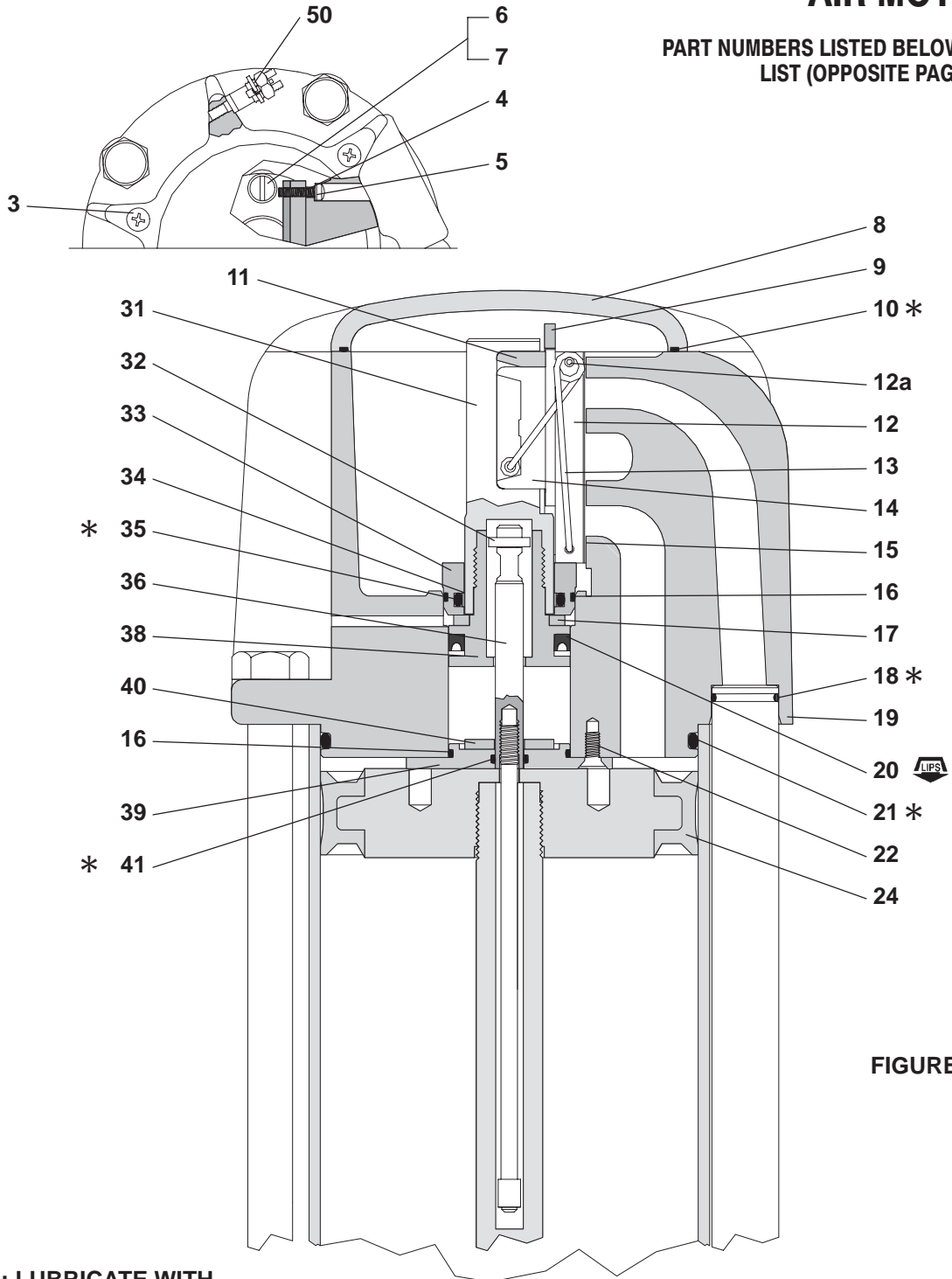

FIGURE 2

\* NOTE: LUBRICATE WITH PARKER "O" RING LUBE (ARO P/N 36460).

NOT SHOWN  
93897-1 Pipe Plug (models 65440 only)

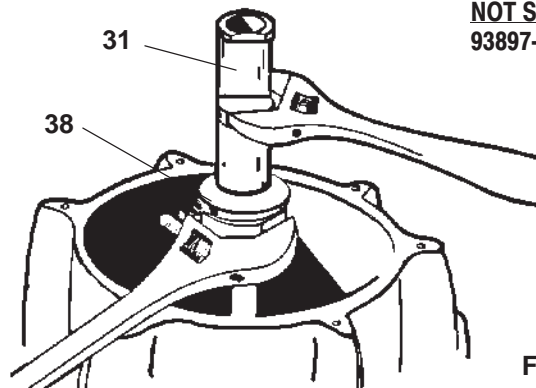

FIGURE 3

# AIR MOTOR PARTS LIST

\* AIR MOTOR MODEL NO.

- INDICATES WHERE PARTS ARE USED.
- MODELS NO LONGER ACTIVE, SHOWN FOR REFERENCE ONLY.

ITEM	DESCRIPTION	PART # (QTY)	61777	65420-1	65440	65441-B	65442-B	65443-B	65443-2B	65444-B	65444-1B	65444-2B	65445-B	65462	65465-B	65465-1B	65466
<input type="checkbox"/> 27	Rod Ass'y	90107-1															
	Rod Ass'y	90107-2															
<input type="checkbox"/> 28	Cylinder	90090-1															
	Cylinder	90090-2															
29	Tube	79008															
	Tube	90101-1															
	Tube	90101-2															
	Tube	94988															
30	Base & Brg (Stub)★	65020															
	Base & Brg (Stub)	65023															
	Base & Brg	65023-2															
	Base & Brg	65025															
	Base & Brg (Stub)	65775															
	Base & Brg (Stub)	65775-2															
	Base & Brg (Stub)	90074															
42	Bolt (1/2" - 20 x 10-1/4")	94046-1 (4)															
	Bolt (1/2" - 20 x 8-1/4")	94046-2 (4)															
<input type="checkbox"/> 43	Snap Ring (1.456" o.d.)	Y147-131															
<input type="checkbox"/> 44	Washer	73986															
<input checked="" type="checkbox"/> 45	"U" Cup (1/4" x 1-1/4" o.d.)	Y186-16															
<input type="checkbox"/> 46	Washer	90103															
47	Nut (1/2" - 20)	Y11-8-C (4)															
<input type="checkbox"/> 48	Rod (see page 8)	61776															
	Rod (see page 8)	90082															
	Rod (see page 8)	90108-1															
	Rod (see page 8)	65911-2															
	Rod (see page 8)	90573															
	Rod (see page 8)	90595															
	Rod (see page 8)	66628															
	Rod (see page 8)	93289															
	Rod (see page 8)	93964															
<input checked="" type="checkbox"/> 49	"O" Ring (1/8" x 1" o.d.)	Y325-210															
	"O" Ring (1/8" x 1 - 5/8" o.d.)	Y325-220															
52	Pipe Plug (1/8" - 27 n.p.t.)	Y17-10-C															

"Smart Parts", Keep these items on hand in addition to the service kits for fast repair and reduction of downtime.

\* See model plate on (30) base for number.

INDICATES WHERE PARTS ARE USED.

PARTS SO MARKED ARE INCLUDED IN 61268 SERVICE KIT.

NOTE: Base styles and lower packings may vary from that shown on the cover. Refer to model number in the chart above.

For simplification of ordering and stocking, a Y325-210 "O" ring, Y325-220 "O" ring and a Y186-16 "U" cup will be included in 61268 service kit. When repairing the motor, use only the one that is needed.

All of the service parts are the same for all motors except the lower piston rod packing.



90350 INSTALLATION TOOL

NOTE: It is highly recommended that a 90350 installation tool be used. This will greatly ease installation of (38) adapter and piston valve and will reduce the chances of damage to the (20) "U" cup. A damaged (20) "U" cup can usually lead to air motor failure.

★ On model 65440 and 65462 air motors, a plate is mounted on the bottom of the (30) base. Therefore, the following parts are different and illustrated on page 8.

- 93310 Bushing
- 93311 Retainer
- 93312 Guide
- 93313 Plate (note the orientation of the plate with the air inlet)
- 93958 Plate (note the orientation of the plate with the air inlet)
- Y6-66-C Screw (4 req'd)
- Y14-616-C Lock Washer (4 req'd)

\* NOTE: LUBRICATE WITH PARKER  
"O" RING LUBE (ARO P/N 36460).

## AIR MOTOR PISTON ROD AND BASE

SEE CHART ON OPPOSITE PAGE FOR EACH MODEL.

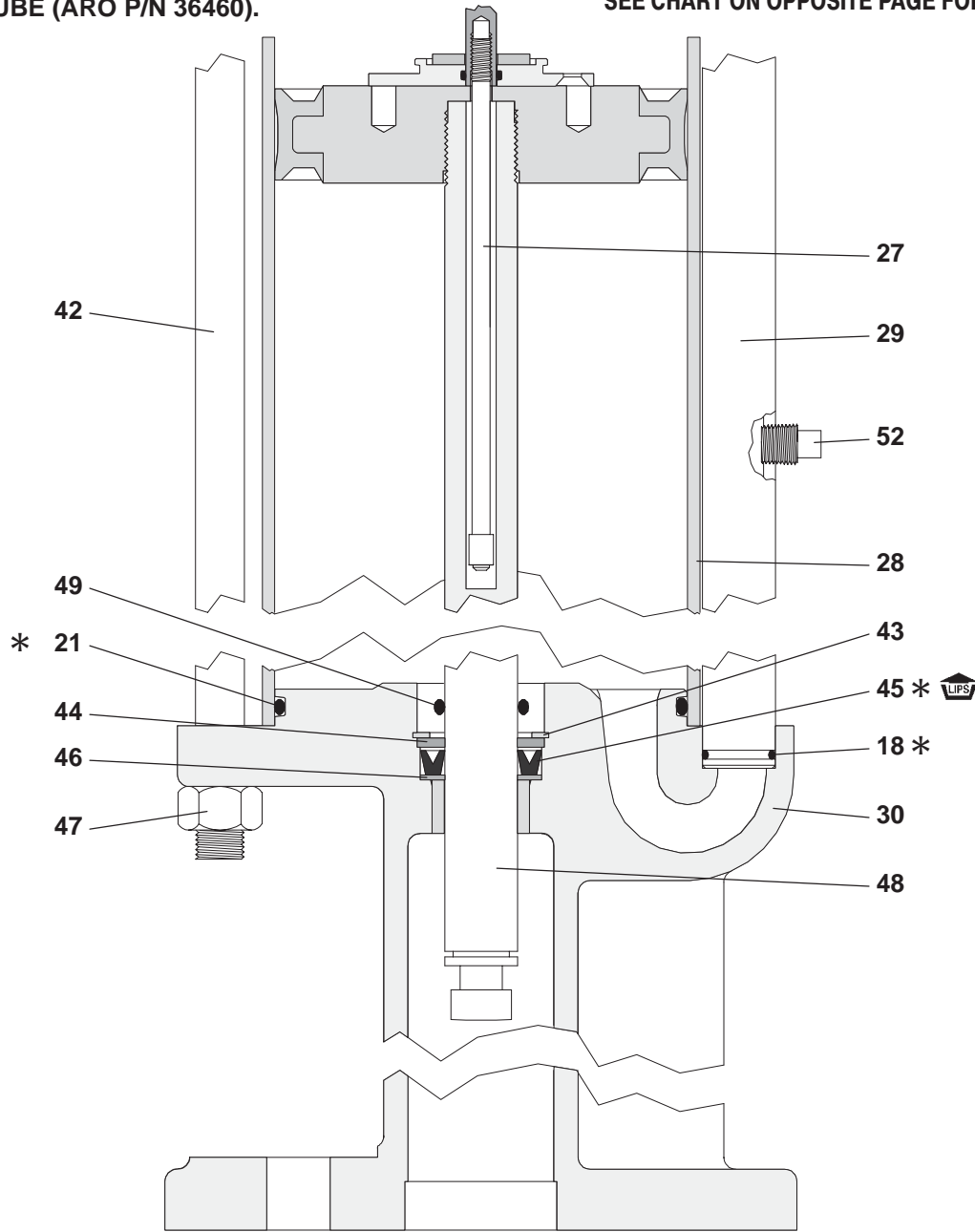

FIGURE 4

### DISASSEMBLY OF AIR MOTOR (CONTINUED)

21. Remove (19) head assembly and place on the workbench with (8) cap side down. This action will allow (40) washer to fall out of its cavity.
22. Remove (21) "O" ring from (19) head assembly.
23. Remove four (22) screws from (39) gland, permitting gland to be removed from (19) head assembly.
24. Remove (16 and 41) "O" rings from (39) gland.
25. Remove (29) tube assembly from (30) base.
26. Remove two (18) "O" rings from (29) tube.
27. Remove (28) cylinder from (30) base. Usually during this step, the (24) piston and (48) piston rod will remain in (28) cylinder.
28. From (30) base assembly (there are 2 types):
  - Type 1 (see figure 4, above): Remove (43) snap ring, (44) washer, (45) "U" cup and (46) washer.
  - Type 2 (see figure 10, page 8): Remove (49) "O" ring.
29. Remove (21) "O" ring from (30) base assembly.
30. Separate (48) piston rod and (24) piston assembly from (28) cylinder.
31. Unscrew (36) extension rod from (27) rod assembly by holding (27) rod assembly with adjustable type pliers and placing a wrench on the provided wrench flats at the top of (36) extension rod.
32. Unscrew (48) piston rod from (24) piston assembly. Use provided wrench flats on (48) piston rod. Next, remove (27) rod assembly from (48) piston rod.

NOTE: Caution should be exercised so as not to mar or damage the finish on (36) extension rod or (48) piston rod.

## REASSEMBLY OF AIR MOTOR

1. Apply grease to all "O" rings, "U" cups and other rubber goods before installing.
2. Clean the threads on (27) rod assembly and put the threaded end thru (24) piston assembly.
3. Hold (27) rod assembly below threads with locking type pliers. After applying Loctite 271 to the threads, attach (36) extension rod and draw up tight, using the wrench flats provided on (36) extension rod.  
**NOTE: Do not mar or damage the surface of (36) extension rod.**
4. Place the "machined shoulder" end of (27) rod assembly into the hole in the end of (48) piston rod. After applying Loctite 271 to threads, secure (48) piston rod into (24) piston assembly and tighten to 50 - 60 ft lbs, using provided wrench flats on (48) piston rod.  
**NOTE: Do not mar or damage the surface of (48) piston rod.**
5. Install (21) "O" ring on (30) base assembly.
6. On type one (30) base assembly (see figure 4, page 5), install (46) washer, (45) "U" cup (lips up), (44) washer and (43) snap ring. On type two (30) base assembly (see figure 10, page 8), install (49) "O" ring.
7. Push (48) piston rod thru (30) base assembly, being careful not to damage the lips of (45) "U" cup or (49) "O" ring.
8. Grease the inside of (28) cylinder and fill the area between the lips of (24) piston assembly with grease, then place (28) cylinder over (24) piston and rod assembly (see figure 5 below).

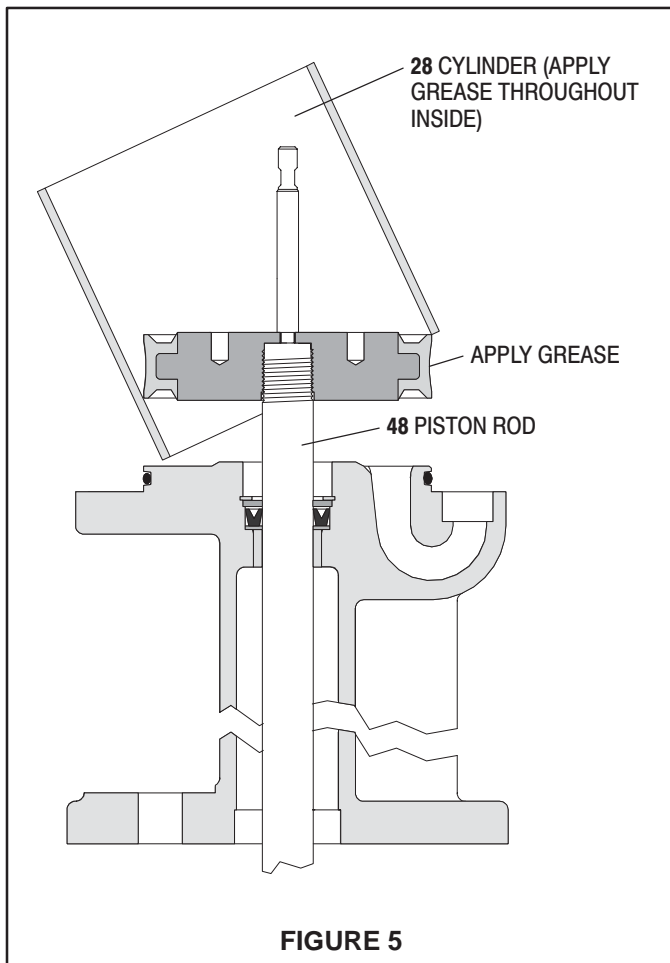

FIGURE 5

9. Push (24) piston assembly to the top of (28) cylinder.
10. Install two (18) "O" rings on (29) tube and insert (29) tube assembly into provided hole of (30) base assembly.
11. Install (16 and 41) "O" rings on (39) gland.
12. Grease the bore in (19) head assembly and insert (39) gland assembly into bore of (19) head assembly with a twisting motion.
13. Align holes in (39) gland and (19) head assembly and secure with four (22) screws.
14. Install (21) "O" ring on (19) head assembly.
15. Push (36) extension rod thru (41) "O" ring in the base of (19) head assembly.
16. Press (19) head assembly down, seating against (28) cylinder and (29) tube assembly.
17. Insert four (42) bolts down thru the holes in the flange of (19) head assembly and (30) base assembly.
18. Screw four (47) nuts on (42) bolts. Alternately and evenly tighten four (47) nuts.
19. Install (20) "U" cup in (38) adapter, with the lips down toward the thick flange of (38) adapter.
20. Install (35 and 16) "O" rings in the (33) gland.
21. Bend (34) seal in a heart shape (see figure 6 below) and install in (33) gland, next to (35) "O" ring (see figure 7 below).

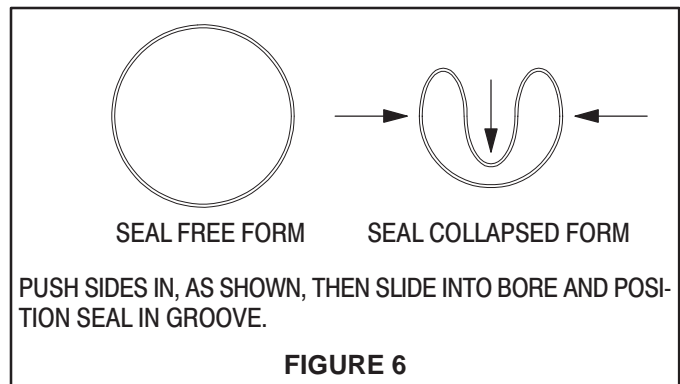

FIGURE 6

22. Carefully push (31) valve piston into (33) gland to size (34) seal (see figure 7 below). After sizing, remove (31) valve piston from (33) gland.

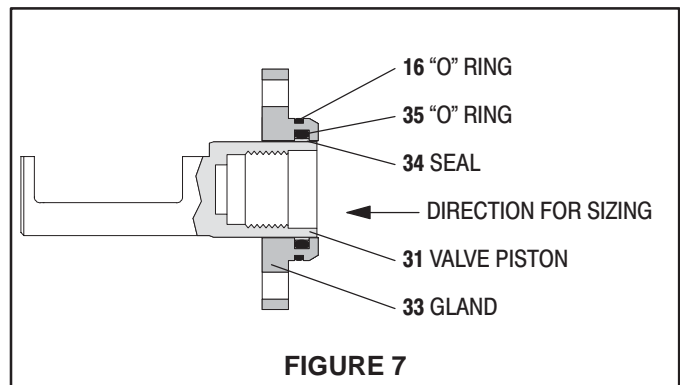
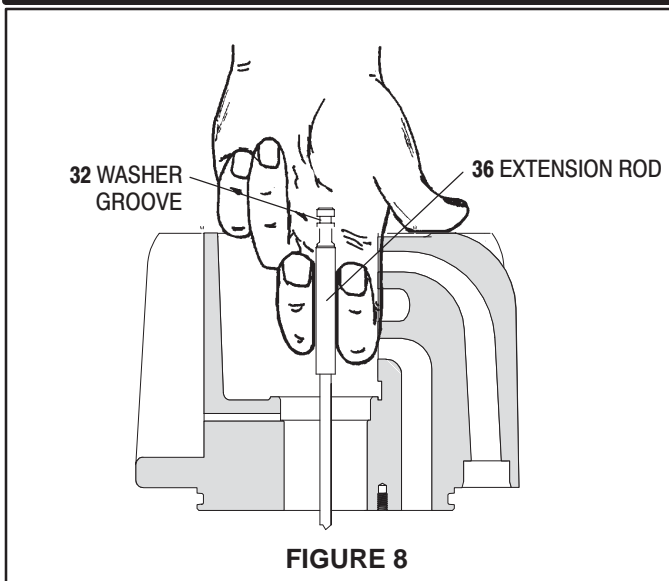

FIGURE 7

23. Slide (40) washer over (36) extension rod.
24. Pull (36) extension rod up and grasp with two fingers (see figure 8, page 7).
25. Place 90350 special installation tool over (36) extension rod, with turned diameter down and the chamber side up.



**FIGURE 8**

26. Fit the turned diameter of the 90350 special installation tool into the bore in the bottom of (19) head assembly.
27. Place (38) adapter assembly down over (36) extension rod, with the thread on the (38) adapter up.
28. Insert (32) washer into the groove on the top of (36) extension rod.
29. Pull (38) adapter up around the (32) washer.
30. Place (17) washer over (36) extension rod and onto (38) adapter.
31. Clean with solvent and put Loctite 271 on the threads of (38) adapter. Screw (31) valve piston onto (38) adapter and tighten (see figure 3, page 3).
32. Push the assembled (38) adapter and (31) valve piston down thru the 90350 special installation tool until it bottoms.
33. Remove the 90350 special installation tool by pulling up on it.
34. Install (33) gland assembly over the (31) valve piston and push down, being careful to retain (34) seal in the "O" ring groove.
35. Align the two screw holes and secure (33) gland assembly to (19) head assembly with two (6) screws and two (7) lock washers.
36. Insert (13) insert spring assembly into the (19) head assembly, with the hooks down and the nylon roller toward (31) valve piston.
37. Apply grease to both (11 and 14) inserts and place them in position (see figure 9) with legs of insert toward (31) valve piston and the larger, (14) insert, located in front of the larger diameter nylon roller. Also, the nylon roller on the (13) insert spring assembly should be between the legs of both (11 and 14) inserts.

38. Apply grease to gasket side of (12) valve plate and put (15) gasket on (12) valve plate. To determine the correct side, the screw holes nearest the top and bottom of (12) valve plate are toward the exhaust port on the (19) head assembly. Also, the (12a) roll pins in (12) valve plate are at the top.
39. Hold the (11 and 14) inserts against the (31) valve piston and slide the (15) gasket and (12) valve plate between the two inserts and (19) head assembly. Be sure the larger holes in the (12) valve plate are located in front of the larger or (14) insert. Also, be sure the pins are located at the top of the valve plate.
40. Hook the round coil in (13) insert spring assembly over the (12a) roll pins (see figure 9).
41. Hook the bottoms of the (13) insert spring assembly into the holes on the side of (12) valve plate (see figure 9).
42. Insert (9) valve guide against the face of (12) valve plate. The legs of (9) valve guide should be down, with the leg having the threaded hole nearest the bottom located nearest the exhaust port of the (19) head assembly.
43. Place (5) washer on each of the four (4) screws and insert into the provided holes and tighten evenly across the corners. NOTE: To ease the alignment of the holes, an "O" ring pick is helpful.
44. Install (10) gasket in (8) air motor cap and secure with six (3) screws.
45. Place (2) deflector on the exhaust port of (19) head assembly, with the opening down, and secure with four (1) screws.

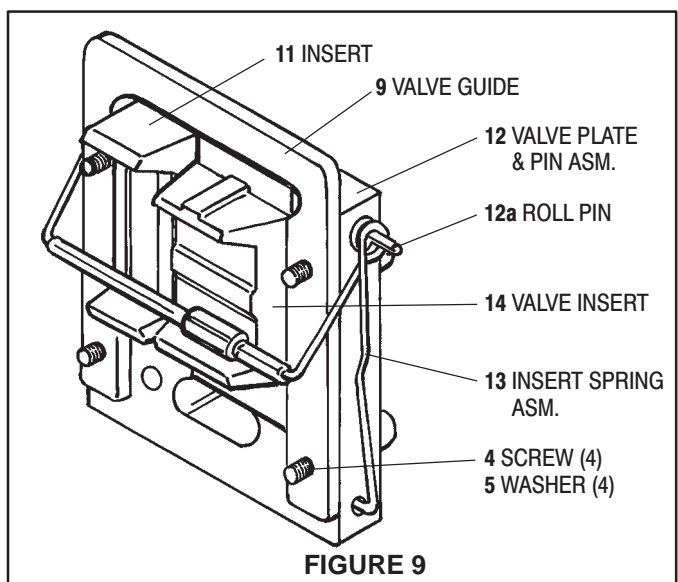
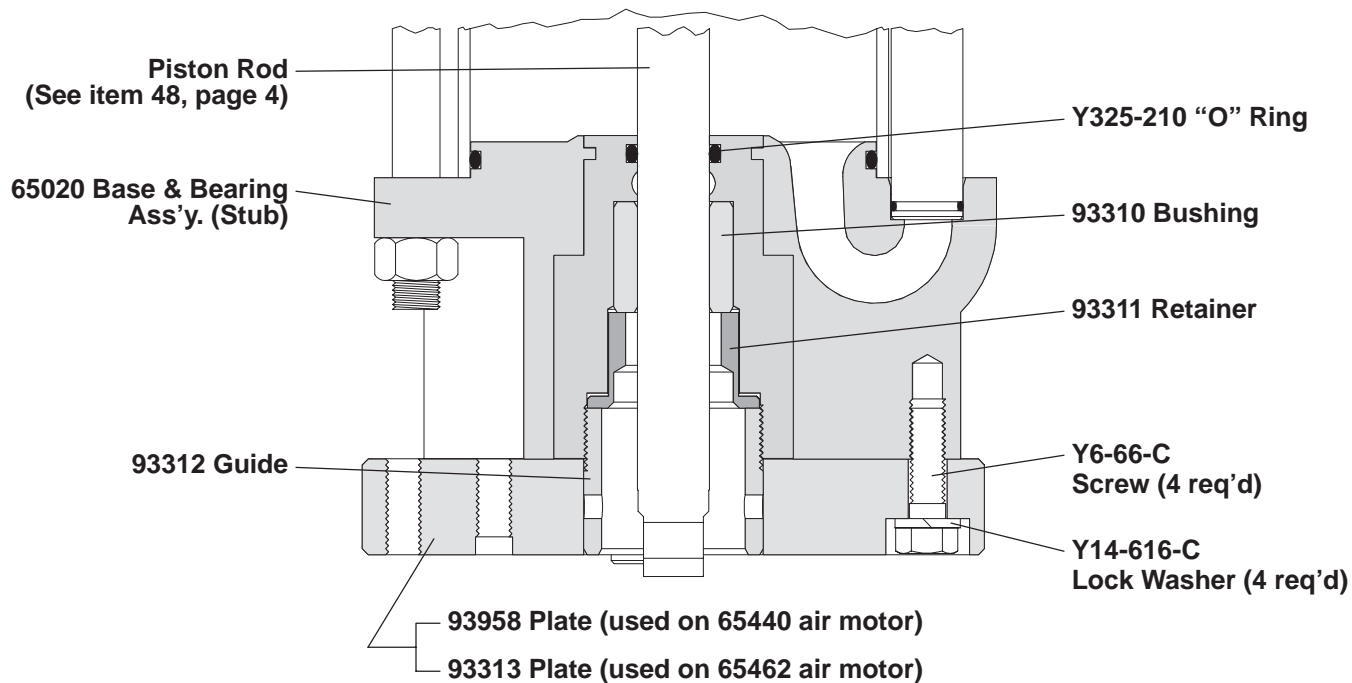

**FIGURE 9**

**TROUBLE SHOOTING**

<p><b>PROBLEM</b> Air leakage out of main exhaust.</p> <p><b>CAUSE</b> Worn (14) insert.</p> <p><b>REMEDY</b> Replace (14) insert.</p> <p><b>CAUSE</b> Worn (12) valve plate and pin assembly.</p> <p><b>REMEDY</b> Replace (12) valve plate and pin assembly.</p> <p><b>CAUSE</b> Damaged (24) piston assembly.</p> <p><b>REMEDY</b> Replace (24) piston assembly.</p>	<p><b>PROBLEM</b> Continual air leakage out of bleeder hole in (19) head assembly.</p> <p><b>CAUSE</b> Worn (35) "O" ring or (34) seal.</p> <p><b>REMEDY</b> Replace (35) "O" ring and (34) seal.</p> <p><b>PROBLEM</b> Air leakage around (48) piston rod.</p> <p><b>CAUSE</b> Worn (45) "U" cup.</p> <p><b>REMEDY</b> Replace (45) "U" cup.</p>
---	---

# 65440 AND 65462 AIR MOTOR PISTON ROD & BASE



## ITEM 48 PISTON ROD END VARIETY

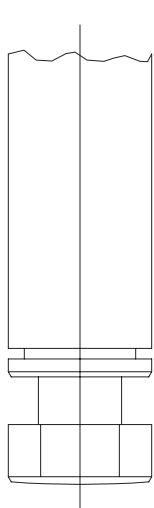

65911-2 Piston Rod  
90108-1 Piston Rod

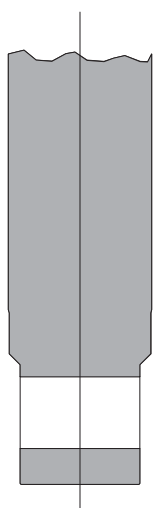

90573 Piston Rod  
93964 Piston Rod

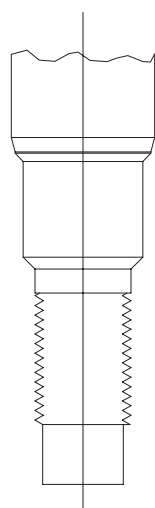

61776 Piston Rod  
66628 Piston Rod  
90595 Piston Rod

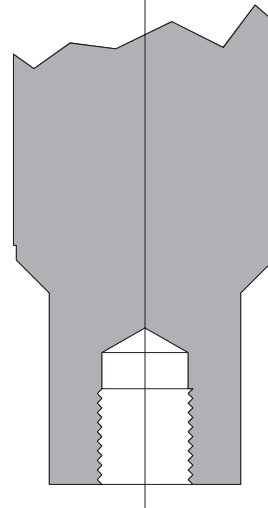

90082 Piston Rod  
93289 Piston Rod