

OPERATOR'S MANUAL

651615-X-B

SPECIFICATIONS, SERVICE KITS, GENERAL INFORMATION
INCLUDE MANUALS: S-635 GENERAL INFORMATION MANUAL (PN 97999-635).

RELEASED: 8-14-98
REVISED: 1-5-01
(REV. B)

651615-X-B SINGLE POST LIFT / RAM

For use with 5 gallon drums (tapered or straight)



**READ THIS MANUAL CAREFULLY BEFORE INSTALLING,
OPERATING OR SERVICING THIS EQUIPMENT.**

It is the responsibility of the employer to place this information in the hands of the operator. Keep for future reference.

SERVICE KITS

- Use only genuine ARO® replacement parts to assure compatible pressure rating and longest service life.
- **104158** for repair of 127112-000 regulator.
- **104176** for repair of F25241-100 filter.
- **104177** for repair of R27241-600 regulator.
- **116772** for repair of E512LM valve.

SPECIFICATIONS

Model Series	651615-X-B
Maximum Working Pressure	160 p.s.i. (11.0 bar)
Base Dimensions	20" square (508 mm)
Height (lowered) (models 651615-B)	36-3/4" (933.5 mm)
Height (lowered) (models 651615-1-B)	41-1/8" (1044.6 mm)
Height (raised) (models 651615-B)	56-1/4" (1428.8 mm)
Height (raised) (models 651615-1-B)	60-5/8" (1539.9 mm)

GENERAL DESCRIPTION

The ARO model 651615-1-B single post lift / ram uses a 3-1/2" air powered cylinder which is welded to a heavy gauge base. It is normally used to raise and lower a fluid handling pump and follower in and out of a standard 5 gallon drum, or when used as a ram, it can force high viscosity flowable material into the pump inlet.

When properly secured, this unit has the ability to raise a pump to clear a standard 5 gallon drum. The operator is then able to easily remove the pump from the drum.

This lift / ram uses a hand lever 4-way control valve which controls the air necessary to raise and lower the lift / ram. This unit includes an auxiliary manual air valve which is used to supply a controlled amount of air pressure to the bottom of the follower plate. When the control valve is in the "up" position, a small amount of air pressure applied under the follower plate will help to raise the follower plate, pump and lift / ram by relieving the vacuum (see page 2).

IMPORTANT

This is one of the five documents which support the system. Replacement copies of these forms are available upon request.

- 651615-X-B MODEL OPERATOR'S MANUAL
- GENERAL INFORMATION - AIR OPERATED LIFTS AND RAMS
- 1251X1-XXX MINIATURE F-R-L OPERATOR'S MANUAL
- F252XX-XXX FILTER OPERATOR'S MANUAL
- R272X1-XXX REGULATOR OPERATOR'S MANUAL

OPERATING AND SAFETY PRECAUTIONS

⚠ WARNING READ THE GENERAL INFORMATION MANUAL INCLUDED FOR OPERATING AND SAFETY PRECAUTIONS AND OTHER IMPORTANT INFORMATION.

⚠ WARNING DO NOT EXCEED MAXIMUM AIR INLET PRESSURE OF 160 P.S.I. (11 BAR).

PUMP DATA

651615-X-B SINGLE POST LIFT / RAM

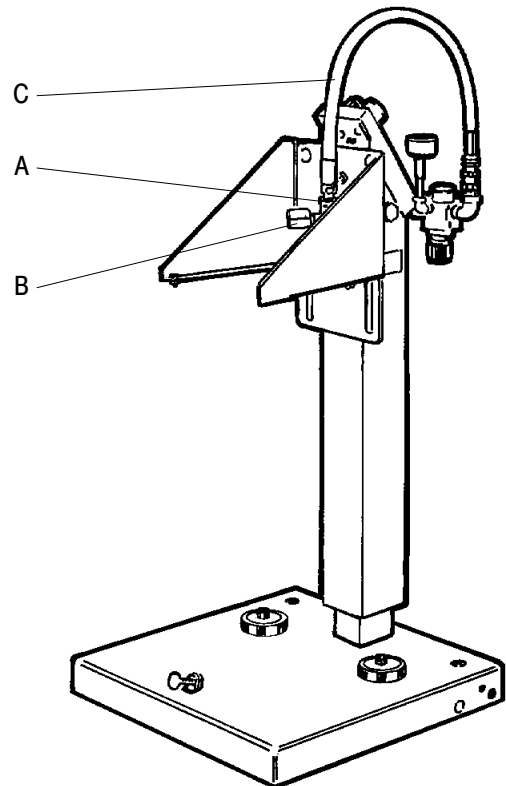

FIGURE 1

PARTS LIST

ITEM	DESCRIPTION (Size in Inches)	QTY	PART NO.
A	90° Street Elbow (1/2 - 14 N.P.T.)	(1)	Y43-4-C
B	Adapter (1/4 - 18 N.P.T. x 1/2 - 14 N.P.T.)	(1)	Y167-5
C	Air Hose (1/2 - 14 N.P.T.F. x 2' long)	(1)	621501-2
■ D	Cap Screw (3/8" - 16 x 3/4") (not shown)	(4)	Y6-63-C
■ E	Washer (3/8") (not shown)	(4)	Y13-6-C

- Items used to mount pump to mounting plate.



INSTALLATION

1. Establish the desired location for the lift / ram and pay attention to the work area above. This area above the lift must be open, without obstructions and safely away from any electrical devices.
2. Place the pump on the follower plate and align the pump and follower plate on the base and assemble the pump to the mounting bracket on the ram.

3. Assemble the air hose to the air motor inlet.
 4. Install the check and follower plate air hose from the control valve.
 5. Assemble the vent plug to the follower plate.
- NOTE: The lift / ram was tested at the factory. The unit should be generally checked over for leakage because the fittings on the system may have loosened during shipment.

OPERATING INSTRUCTIONS

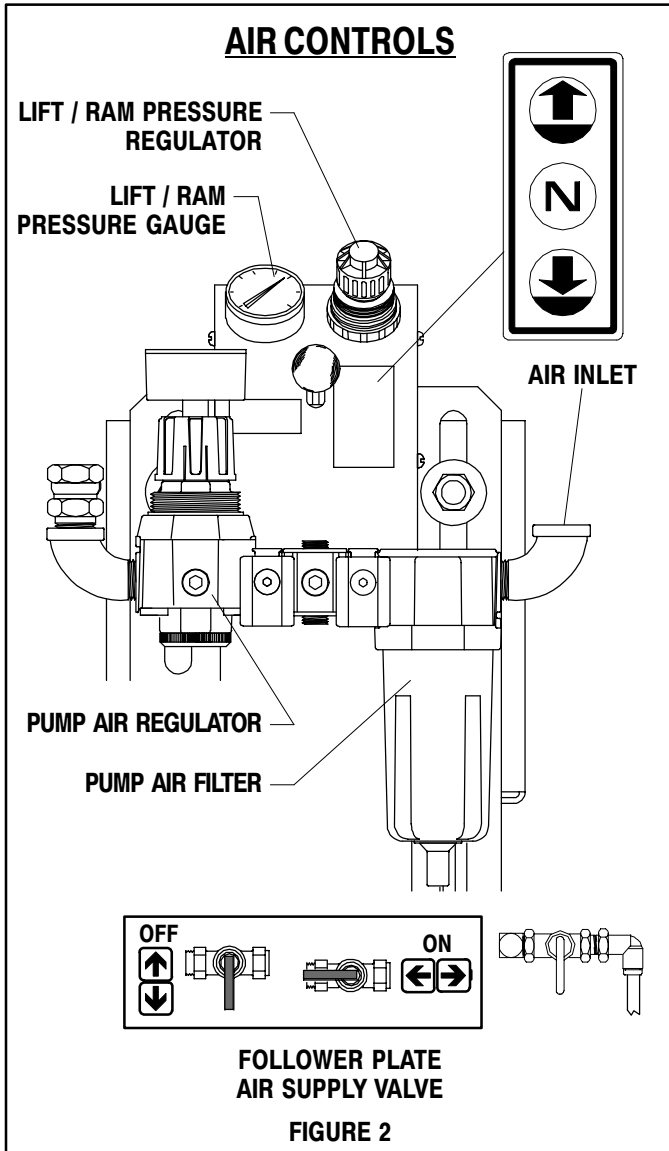

TO RAISE LIFT:

1. Take note of the pump / drum clearance above. Be certain the lift / ram is clear of any objects above. Also refer to "Operating and Safety Precautions" found in "Lifts and Rams General Information Manual" (pn 97999-635).
2. Connect the air supply (160 PSI MAX.) to the air inlet. Adjust air pressure on lift / ram pressure regulator (turn knob clockwise) to 20 p.s.i. (1.4 bar).
3. Shift the control valve lever to the "up" position.
4. Raise the lift / ram high enough to clear the height of the drum. Stop the lift / ram's upward travel by moving the control valve lever to the "neutral" (center) position.

REFER TO PAGE 3:

1. Once the lift / ram assembly and pump are in the "up" position, place and center an opened 5 gallon drum of material on the lift / ram base. Use the stops on the base to center the 5 gallon drum. Tighten thumb screw to secure drum.
2. Lubricate lower follower wiper plate seal with grease. NOTE: Make certain the grease is compatible with the material being dispensed. This ensures a smooth fit into the pail as well as prevents curing type compounds from bonding to seal.
3. Check vent plug on follower plate to be sure it easily threads in and out. It is recommended to lubricate the threads of the plug to help prevent possible set up of compound at this point.

TO LOWER LIFT:

⚠ WARNING PINCH HAZARD. Follower can descend quickly causing injury. Keep hands clear when aligning with container.

NOTE: Be certain the follower plate vent plug has been removed so that the air trapped between the follower and the material is allowed to escape from this vent. Captured air between the follower plate and drum will escape.

NOTE: The lift / ram may hesitate momentarily before starting downward. The air pressure inside the post air chamber must decrease before it will begin to descend.

1. Shift the control valve lever to the "down" position and proceed to lower the pump.
2. Replace the vent plug once the material begins to ooze from the vent opening.
3. The unit is now ready for operation. Adjust the air pressure on the pump filter / regulator (turn pump regulator knob clockwise) until the pump begins to cycle.
4. Trigger gun to prime pump with material.

TO RAISE LIFT, (NORMAL OPERATION):

1. Adjust the follower plate air valve pressure up to approximately 8 psig (.55 bar). DO NO OVERPRESSURIZE THE DRUM to avoid damage. NOTE: Air from this valve will only pass when the control valve is in the "up" position.
2. Shift the control valve lever to the "up" position.
3. Raise the lift / ram high enough to clear the height of the drum. Stop the lift / ram's upward travel by moving the control valve lever to the "neutral" (center) position.

TO CHANGE DRUM:

NOTE: The control valve lever should be in the "neutral" position.

1. Unscrew thumb screw and remove old 5 gallon drum.
2. Place and center a new drum into position. Remove cover. Tighten thumb screw.

PARTS LIST

ITEM	DESCRIPTION (Size in Inches)	QTY	PART NO.
31	Base (models 651615-B)	(1)	66558-1
	(models 651615-1-B)	(1)	66558-2
32	Washer (1/4")	(3)	Y13-4-C
33	Nut (1/4" - 20)	(3)	Y12-4-C
34	Carriage Bolt (1/2" - 13 x 1")	(4)	Y84-801-C
35	90° Male Fitting (1/8 - 27 N.P.T.)	(1)	59756-4
36	Tube (models 651615-B)	(1)	94823
	(models 651615-1-B)	(1)	94823-1
37	Rod (models 651615-B)	(1)	94824
	(models 651615-1-B)	(1)	94824-1
38	"O" Ring (3/16" x 3-1/4" o.d.)	(1)	Y325-336
39	Retaining Spring Wire	(1)	90503
40	Plate	(1)	91396
41	Screw (1/4" - 20 x 5/8")	(4)	Y6-42-C
42	Nut (1/4" - 20)	(4)	Y12-4-C
43	Washer (1/4")	(4)	Y13-4-C
44	Bracket	(1)	93968
45	Male Fitting	(3)	59764-4
46	90° Male Fitting (1/4 - 18 N.P.T.)	(3)	59756-154
47	"E" Series 4-Way Valve	(1)	E512LM
48	Self-Tapping Screw (1/4" - 14 x 1")	(2)	Y334-108-C
49	Plug (1/8 - 27 N.P.T.)	(1)	Y17-50
50	Washer (3/8")	(1)	Y13-6-C
51	Spring	(1)	38226
52	Retainer	(1)	94821
53	Hose Coupling (1/8 - 27 N.P.T.F.)	(1)	3249
54	Washer (7/8")	(1)	Y13-14-C
55	Tubing (5/32" o.d. x 5-3/8" long)	(1)	94981-XXX-X
56	Plug	(1)	92389
57	"O" Ring (1/16" x 7/8" o.d.)	(1)	Y325-18

ITEM	DESCRIPTION (Size in Inches)	QTY	PART NO.
58	Piston	(1)	94005
59	Pipe Fitting (1/4 - 18 N.P.T. x 1-1/16")	(1)	Y43-42-C
60	Nipple (1/4 - 18 N.P.T. x 2")	(1)	Y44-11-C
61	90° Street Elbow	(1)	Y43-2-C
62	Nipple (1/4 - 18 N.P.T. x 4")	(1)	Y44-115-C
63	Retaining Ring (2.210" o.d.)	(1)	Y147-200
64	Retaining Washer	(1)	90509
65	Stop	(1)	94006
66	Adapter	(1)	94822
67	Seal	(1)	94010
68	Dowel Pin (1/4" o.d. x 5/8" long)	(1)	Y148-35
69	Cap	(1)	94013
70	Column (models 651615-B)	(1)	66557
	(models 651615-1-B)	(1)	66557-1
71	Backup	(1)	94123
80	"O" Ring (1/16" x 7/8" o.d.)	(1)	Y325-18
	OPTIONAL (available separately)		
72	Gauge (0 - 160 p.s.i.)(0 - 11 bar)	(1)	100067
	Stop & Bracket Assembly		
	(includes items 73 - 79)	(1)	67189
73	Thumb Screw (3/8" - 16 x 1-1/2")	(1)	Y66-378-C
74	Bucket Stop	(2)	90419
75	Carriage Bolt (3/8" - 16 x 1")	(2)	Y84-601-C
76	Nut (3/8" - 16)	(3)	Y12-6-C
77	Lockwasher (3/8")	(2)	Y14-616-C
78	Bracket Assembly	(1)	67182
79	Lockwasher (3/8")	(1)	Y117-616
	<input type="checkbox"/> Bulk Tubing (5/32" o.d. x 100')		

PARTS LIST

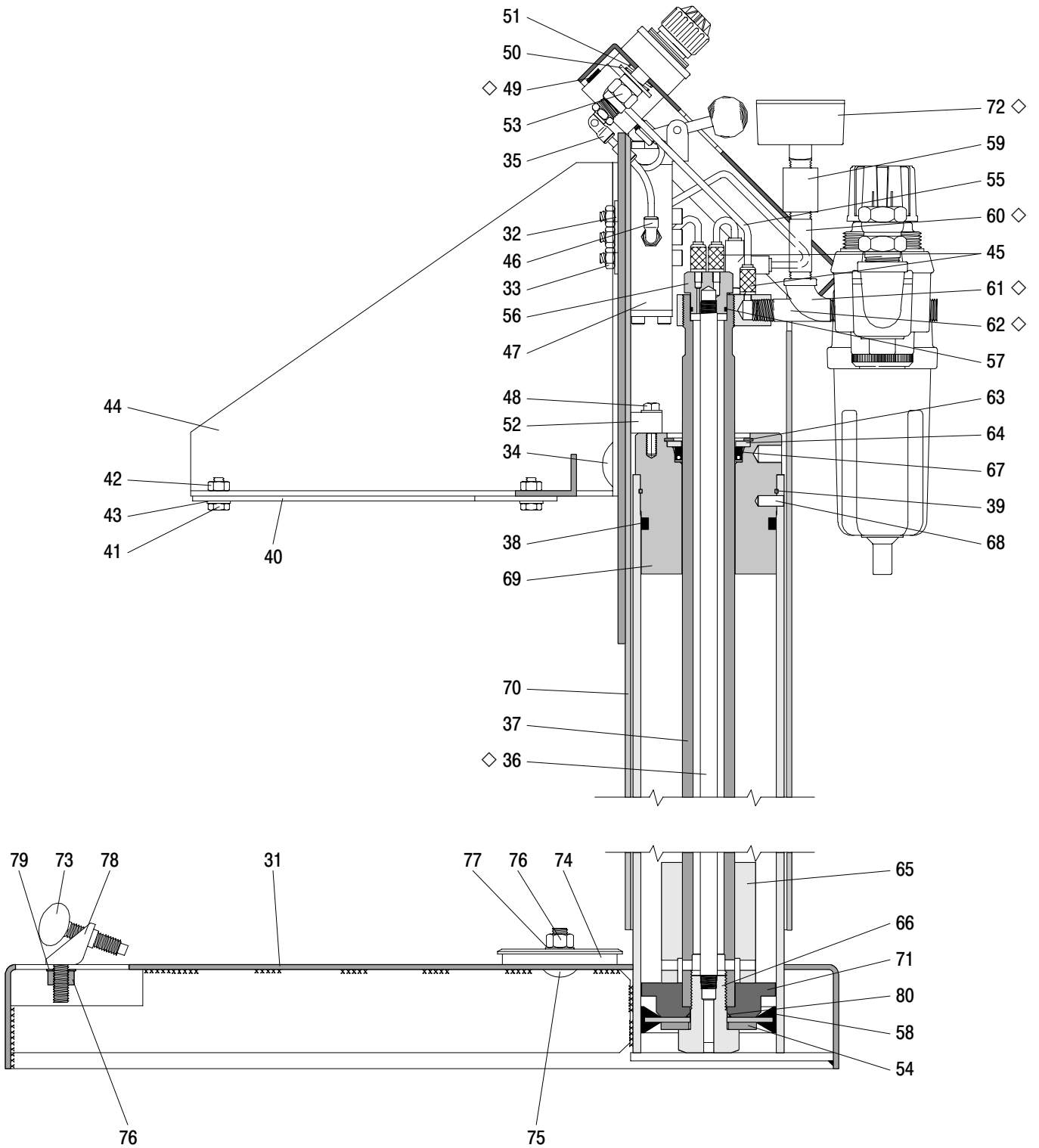

◇ Apply anaerobic pipe thread sealant to male threads at assembly.

FIGURE 5

91396 PLATE

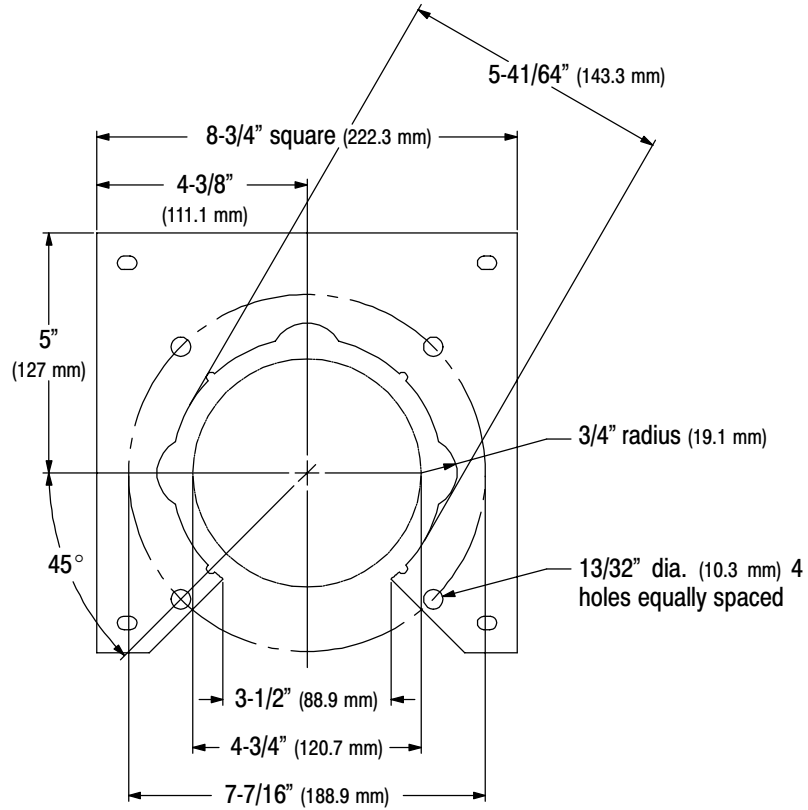

FIGURE 6

66713 PORTABILITY KIT

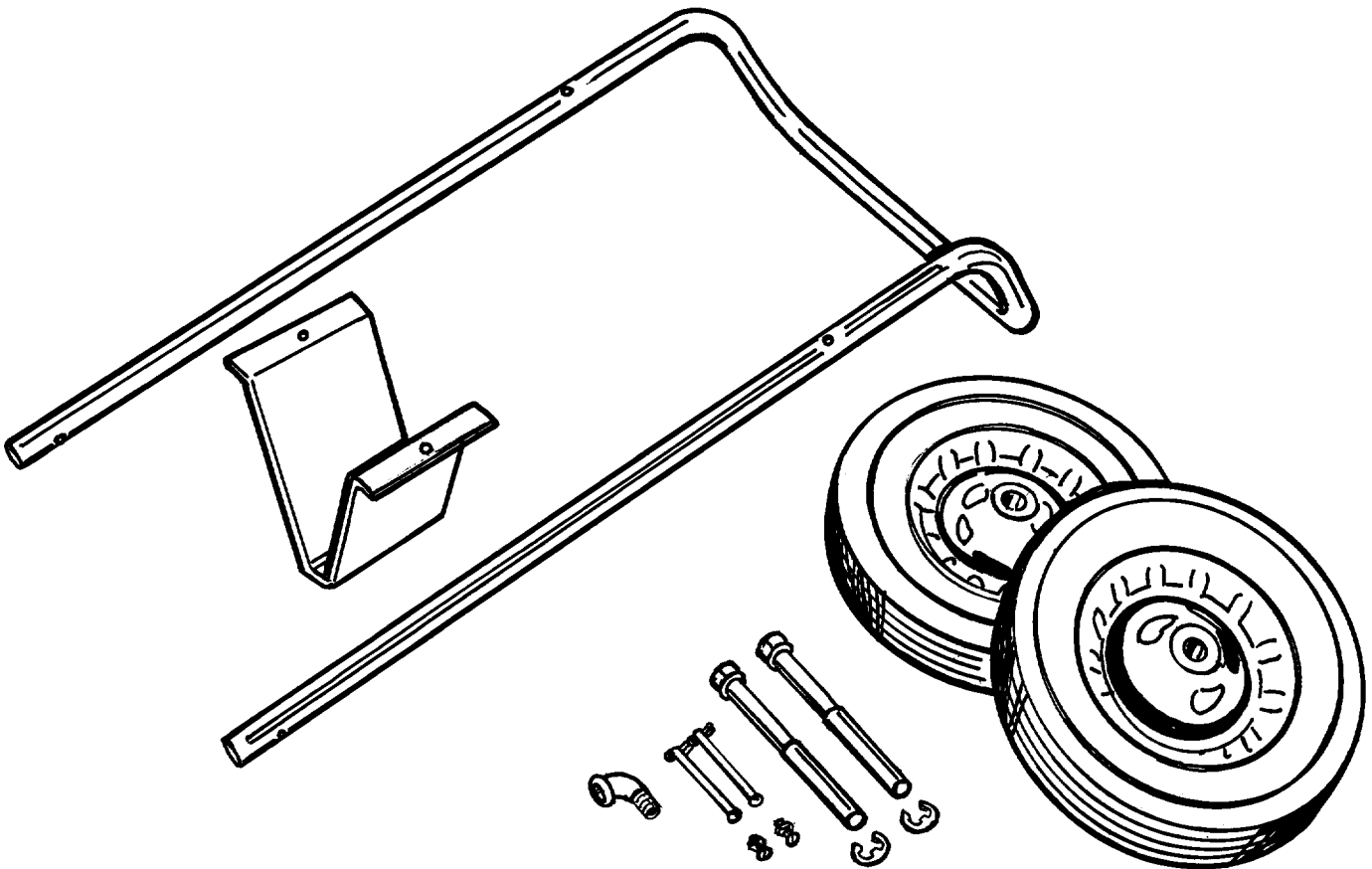

FIGURE 7

