

OPERATOR'S MANUAL

650866-X-B

SPECIFICATIONS, SERVICE KITS, GENERAL INFORMATION, TROUBLESHOOTING

INCLUDE MANUALS: 6694X-X LOWER PUMP END (PN 97999-12) &
S-632 GENERAL INFORMATION MANUAL (PN 97999-624)

RELEASED: 1-14-00

REVISED: 7-25-02

(REV. B)

8" AIR MOTOR
10:1 RATIO
6" STROKE

650866-XXD-B TWO BALL PUMP SERIES 400 SERIES STAINLESS STEEL



**READ THIS MANUAL CAREFULLY BEFORE INSTALLING,
OPERATING OR SERVICING THIS EQUIPMENT.**

It is the responsibility of the employer to place this information in the hands of the operator. Keep for future reference.

SERVICE KITS

- Use only genuine ARO® replacement parts to assure compatible pressure rating and longest service life.
- **66614 for repair of Air Motor section.**
Service Note: The Air Motor Service / Parts Manual is not shipped with the pump but it is included with each service kit. If this Service / Parts Information is needed, request the Air Motor Operator's Manual from ARO (manual 66523-B, PN 97999-868).
- **637211-XX3 for repair of Lower Pump section.**
Refer to the chart on page 2 for description of -XXD options.

SPECIFICATIONS

Model Series (refer to option chart)	650866-XXD-B
Type	Air Operated, Two Ball Double Acting Pump
Ratio	10:1
Air Motor	66523-B
Motor Repair Kit	66614
Motor Diameter	8" (20.3 cm)
Stroke	6" (15.2 cm)
Air Inlet (female)	3/4 - 14 N.P.T.F. - 1
Air Exhaust (female)	1-1/4 - 11-1/2 N.P.T.F. - 1
Lower Pump End Series	66941-XXD
Lower Pump Repair Kit	637211-XX3
Material Inlet (male)	2 - 11-1/2 N.P.T.F. - 1
Material Outlet (female)	1-1/4" - 11-1/2 N.P.T.F. - 1
Weight	102 lbs (46.3 kgs)

PERFORMANCE

Air Inlet Pressure Range	30 - 120 p.s.i. (2.1 - 8.3 bar)
Fluid Pressure Range	300 - 1200 p.s.i. (20.7 - 82.8 bar)
Maximum Rec'd Cycles / Minute	70
Displacement In³ Per Cycle	59.8
Volume / Cycle	33.1 oz. (979.6 ml)
Cycles Per Gallon	3.9
Flow @ 70 Cycles / Minute	18.1 g.p.m. (68.6 l.p.m.)
Noise Level @ 60 p.s.i. - 40 c.p.m.	89.8 db (A) *

* The pump sound pressure level has been updated to an Equivalent Continuous Sound Level (L_{Aeq}) to meet the intent of ANSI S1.13-1971, CAGI-PNEUROP S5.1 using four microphone locations.

PUMP DATA

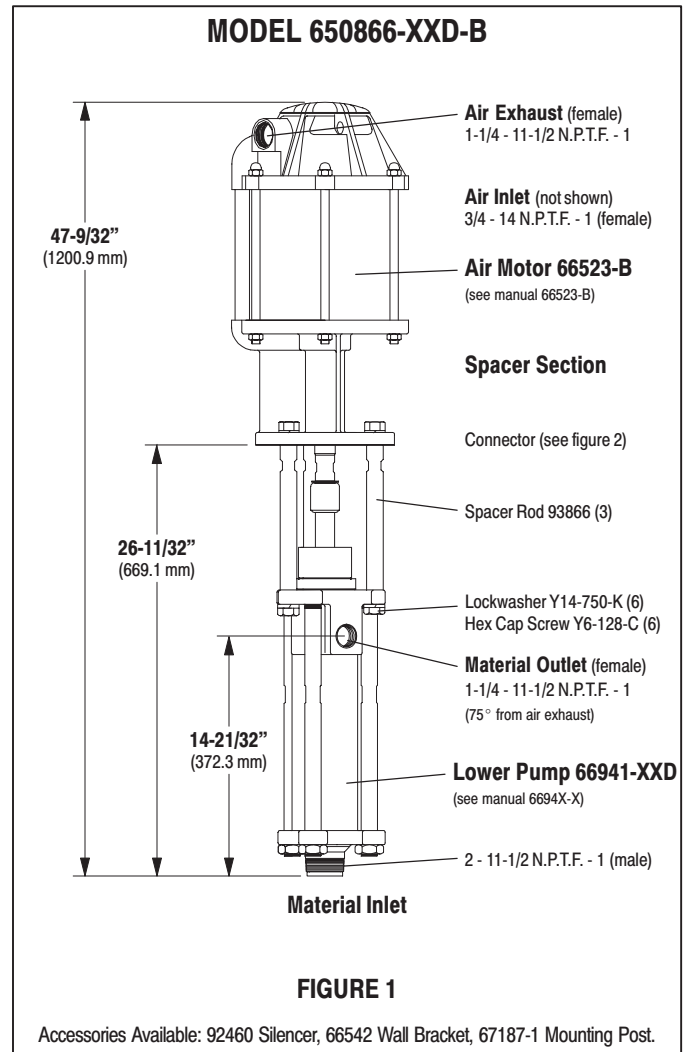

IMPORTANT

This is one of the four documents which support the pump. Replacement copies of these forms are available upon request.

- 650866-X-B MODEL OPERATOR'S MANUAL
- GENERAL INFORMATION - INDUSTRIAL PISTON PUMPS
- 6694X-X LOWER PUMP END OPERATOR'S MANUAL
- 66523-B AIR MOTOR OPERATOR'S MANUAL



PUMP OPTION DESCRIPTION CHART

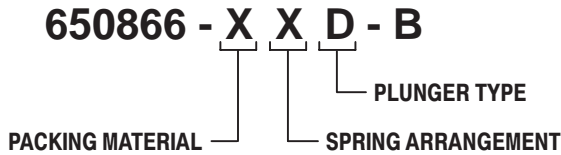

PACKING MATERIAL (PACKINGS ARE UPPER AND LOWER UNLESS NOTED)

C UHMW-PE	P UHMW-PE / Teflon Staggered (upper)
K Carbon-Graphite filled Teflon	UHMW-PE (lower)
L Mineral filled Teflon	R Teflon / UHMW-PE Staggered (upper)
	Mineral Filled Teflon (lower)

SPRING ARRANGEMENT

6 Wave Spring
D Wave Spring with Alternate Seat Material

PUNGER TYPE

D Hardened Stainless Steel with hard Chrome Plating

GENERAL DESCRIPTION

⚠ WARNING HAZARDOUS PRESSURE. Do not exceed maximum operating pressure of 1200 p.s.i. (82.8 bar) at 120 p.s.i. (8.3 bar) inlet air pressure.

$$\text{PUMP RATIO X} = \frac{\text{MAXIMUM PUMP FLUID PRESSURE}}{\text{INLET PRESSURE TO PUMP MOTOR}}$$

Pump ratio is an expression of the relationship between the pump motor area and the lower pump end area. EXAMPLE: When 120 p.s.i. (8.3 bar) inlet pressure is supplied to the motor of a 5:1 ratio pump it will develop a maximum of 600 p.s.i. (41.4 bar) fluid pressure (at no flow) – as the fluid control is opened, the flow rate will increase as the motor cycle rate increases to keep up with the demand.

⚠ WARNING Refer to general information sheet for additional safety precautions and important information.

- The Two-Ball pumps are primarily designed for the high volume transfer of light and medium viscosity fluids. Stainless Steel construction offers compatibility with a wide range of fluids. The lower pump is designed for easy priming and the double acting feature is standard in all ARO industrial pumps. Material is delivered to the pump discharge outlet on both the up and down stroke.
- The motor is connected to the lower pump end by a spacer section. This allows for lubrication of the upper packing gland and prevents motor contamination because of normal wear and eventual leakage through the material packing gland. Be sure the solvent cup is adequately filled with lubricant to protect the upper packings and insure longest service life.

TROUBLE SHOOTING

Pump problems can occur in either the Air Motor Section or the Lower Pump End Section. Use these basic guidelines to help determine which section is affected.

If the pump will not cycle.

- Be certain to first check for non-pump problems including kinked, restrictive or plugged inlet / outlet hose or dispensing device. Depressurize the pump system and clean out any obstructions in the inlet / outlet material lines.
- Refer to the motor manual for trouble shooting if the pump does not cycle and / or air leaks from the air motor.

If the pump cycles but does not deliver material.

- Refer to the lower pump end manual for further trouble shooting.

PUMP CONNECTION – UPPER / LOWER

NOTE: All threads are right hand.

- Lay the pump assembly on a workbench.
- Remove the three (Y6-128-C) cap screws and (Y14-750-K) lock washers from the three spacer rods (figure 1).
- Pull the air motor from the lower pump end until motor piston rod is in the “down” position and lower pump end rod is in “up” position.
- Remove the three spacer rods by removing the three (Y6-128-C) cap screws and (Y14-750-K) lock washers.
- Using e-ring pliers, slide the “e” ring up far enough to allow the sleeve to move upward and release the two connectors (figure 2).

PUMP CONNECTOR DETAIL

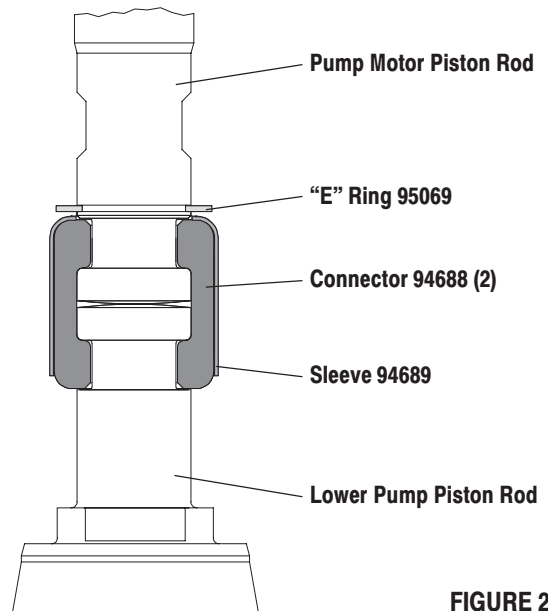

FIGURE 2

REASSEMBLY

- Align the pump motor with the lower pump end. Position the air inlet of the motor 180° from the material outlet.
- Install the two connectors and retain with the sleeve, slide the “e” ring back into position.
- Assemble the three spacer rods to the lower pump and secure using three (Y14-750-K) lock washers and (Y6-128-C) cap screws.
- Reinstall the spacer rods to the pump motor.
- Bring the motor and lower pump together and retain with three (Y14-750-K) lock washers and (Y6-128-C) cap screws.