

# OPERATOR'S MANUAL

# 640169

INCLUDING: OPERATION, INSTALLATION & MAINTENANCE

RELEASED: 1-15-71  
REVISED: 11-7-00  
(REV. D)

## TWO POST LIFT ASSEMBLY, AIR OPERATED

For use on open type containers, 55 Gallon (400 lb.) size drum



**READ THIS MANUAL CAREFULLY BEFORE INSTALLING,  
OPERATING OR SERVICING THIS EQUIPMENT.**

It is the responsibility of the employer to place this information in the hands of the operator. Keep for future reference.

NOTE: Lift height when extended = 92-1/4".  
Lift height when retracted = 55-1/2".

### ASSEMBLY

Assemble 71155 (4) clamps and 73928 (2) mounting brackets to 65117 (2) basic lift assemblies. Secure in place with Y6-87-C (8) cap screws, Y14-816 (8) lock-washers and Y12-8-C (8) nuts. Mounting brackets should be located 12" down from top of the cap on the basic lift assemblies. Assemble the 70799-1, 72221 and 73927 air line tubes.

With lift completely assembled, place in desired location. Drill holes

in floor, using holes in lift base castings as a guide. Secure lift to floor (center line distance between base castings will be about 29-1/2 inches).

NOTE: If Aro standard duty Regulator is used on this model, it may be mounted on 73928. Mount by using 29831 Regulator Mounting Bracket, in location indicated on drawing. Regulator & Bracket are not included with model.

### OPERATING INSTRUCTIONS

To raise lift, connect air pressure to 77881 nipple.

To lower lift, remove air pressure from 77881 nipple. The lift will come down slowly into position.

### PARTS LIST / 640169 TWO POST LIFT ASSEMBLY

NOTE:  
Pump is not  
included in  
this assembly.

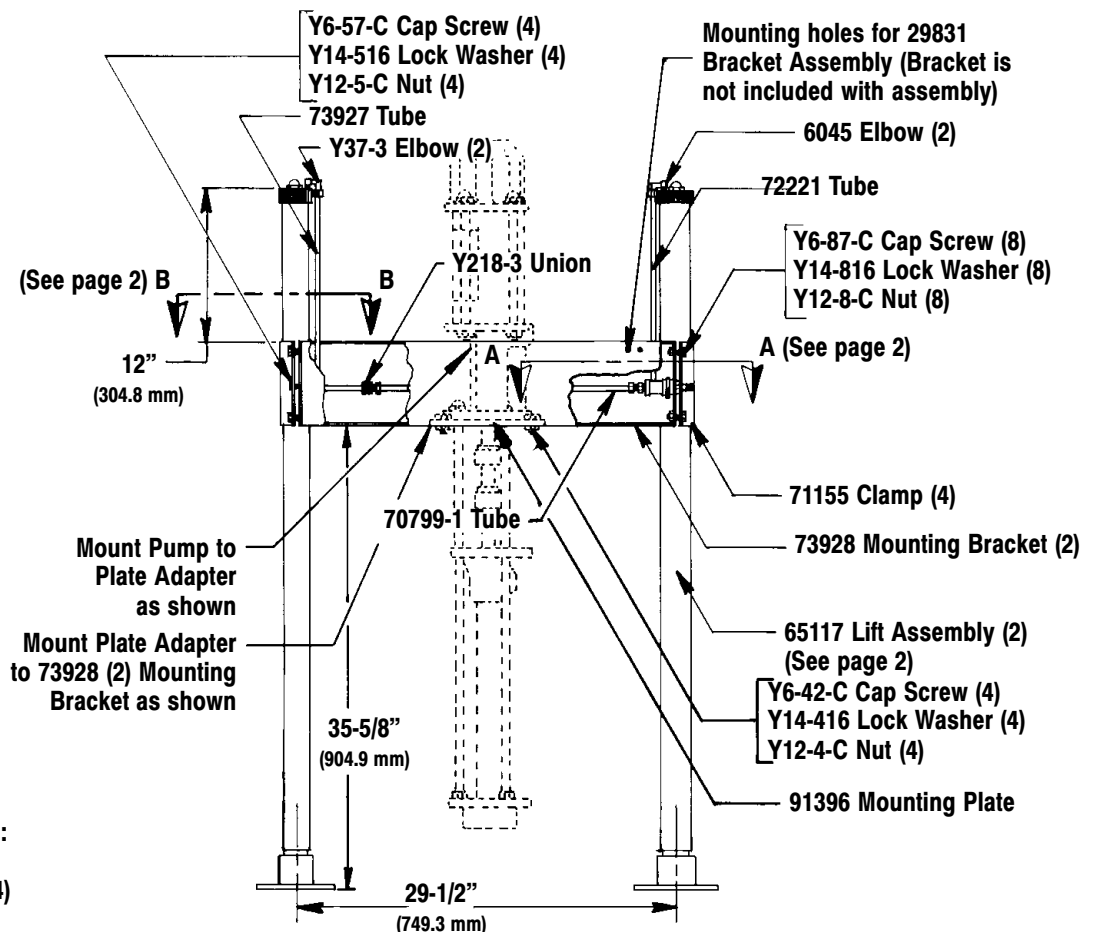

Included but not shown:  
Y6-6-C Cap Screw (4)  
Y14-616 Lock Washer (4)  
Y12-6-C Nut (4)



**PARTS LIST / 65117 BASIC LIFT ASSEMBLY**

