

SALES & ENGINEERING DATA

RATIO SERIES: **1:1**

PF20R-XXX-SXX-B & PF20Y-XXX-SXX-B

FLUID P.S.I. RANGE: **20 - 120**

2" METALLIC FLAP VALVE DIAPHRAGM PUMP

RELEASED: 2-10-05
 REVISED: 3-17-05
 (REV. 02) S-1343

DIMENSIONAL DATA

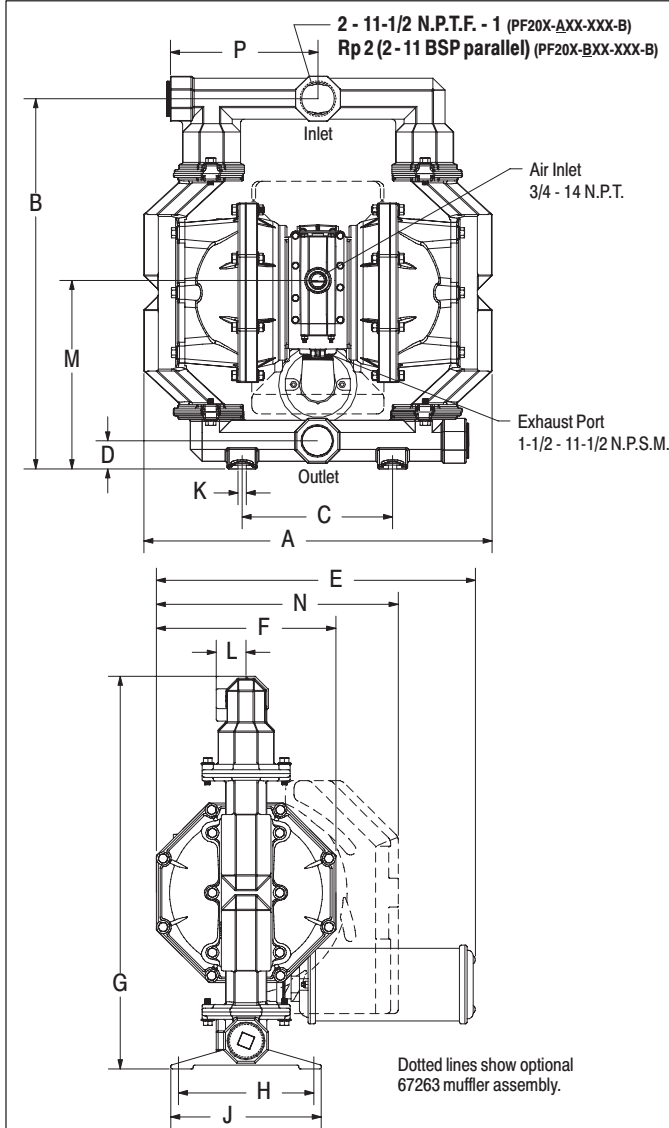

DIMENSIONS

A - 23-9/32" (591.3 mm)	F - 12" (304.8 mm)	L - see below
B - 24-3/4" (628.7 mm)	G - 26-1/4" (666.8 mm)	M - see below
C - 10-1/16" (255.6 mm)	H - 9-1/16" (230.2 mm)	N - 16-3/16" (410.8 mm)
D - see below	J - 10-1/16" (255.6 mm)	P - see below
E - 21-11/32" (541.9 mm)	K - 9/16" (14.3 mm)	

	PF20X-XC X -XXX-B	PF20X-XS X -XXX-B
D -	1-7/8" (47.6 mm)	2-1/2" (63.5 mm)
L -	2" (50.8 mm)	2-3/32" (53.0 mm)
M -	12-19/32" (319.9 mm)	13-1/4" (336.6 mm)
P -	9-7/8" (250.7 mm)	-----

NOTE: Dimensions are shown in inches and (mm), supplied for reference only and are typically rounded up to the nearest 1/16 inch.

SPECIFICATIONS

CONSTRUCTION

Model Series	PF20R-XXX-SXX-B
	PF20Y-XXX-SXX-B
Pump Type	Metallic, Air Operated, Flap Valve, Double Diaphragm
Ratio	1:1
Material Inlet / Outlet (female)	
PF20X-AXX-SXX-B	2 - 11-1/2 N.P.T.F. - 1
PF20X-BXX-SXX-B	Rp 2 (2 - 11 BSP parallel)
Air Inlet (female)	3/4 - 14 N.P.T.
Air Exhaust (female)	1-1/2 - 11-1/2 N.P.S.M.
Weight	
PF20R-XXX-SXX-B	180.8 lbs (82.0 kgs)
PF20Y-XXX-SXX-B	178.7 lbs (81.1 kgs)
Air Section Service Kit	637369
Fluid Section Service Kit	637310-XX

PF20X-XXX-S

X	X
X	X

 -B
 637310 -

X	X
X	X

 Diaphragm Material
 Flap Material
 EXAMPLE: Model # PF20Y-ACP-SAA-B
 Fluid Section Service Kit is 637310-AA

PERFORMANCE

Air Inlet Pressure Range	20 - 120 p.s.i. (1.4 - 8.3 bar)
Maximum Material Inlet Pressure	10 p.s.i. (0.69 bar)
Fluid Pressure Range	20 - 120 p.s.i. (1.4 - 8.3 bar)
Maximum Flow Rate	172 g.p.m. (651 l.p.m.)
Displacement / Cycle @ 100 p.s.i.	1.4 gal. (5.3 lit.)
Maximum Particle Size	2" dia. (50 mm) semi-solids
Maximum Temperature Limits (diaphragm / flap / bumper material)	
E.P.R. / EPDM	-60° to 280° F (-51° to 138° C)
Nitrile	10° to 180° F (-12° to 82° C)
Polyurethane	10° to 150° F (-12° to 66° C)
Santoprene	-40° to 225° F (-40° to 107° C)
T.F.E. (Teflon)	40° to 225° F (4° to 107° C)
Viton	-40° to 350° F (-40° to 177° C)
Noise Level @ 70 p.s.i. - 60 c.p.m.①	85.0 db(A)②

① Tested with 67263 muffler assembly installed.

② The pump sound pressure level has been updated to an Equivalent Continuous Sound Level (L_{Aeq}) to meet the intent of ANSI S1. 13-1971, CAGI-PNEUROP S5.1 using four microphone locations.

ACCESSORIES:

- 66473 Air Line Connection Kit
- 67263 Continuous Muffler Assembly
- 94117 Int. Muffler

PERFORMANCE CURVES

PF20R-XXX-XXX-B / PF20Y-XXX-XXX-B 2" METALLIC FLAP VALVE DIAPHRAGM PUMP

