

SALES & ENGINEERING DATA

PD20A-XXX-XXX-B / PD20S-XXX-XXX-B PE20A-XXX-XXX-B() / PE20S-XXX-XXX-B() 2" METALLIC DIAPHRAGM PUMP

RATIO SERIES:	1:1
FLUID P.S.I. RANGE:	20 - 120
RELEASED:	2-3-05
REVISED:	3-17-05
(REV. 03)	S-1338

DIMENSIONAL DATA

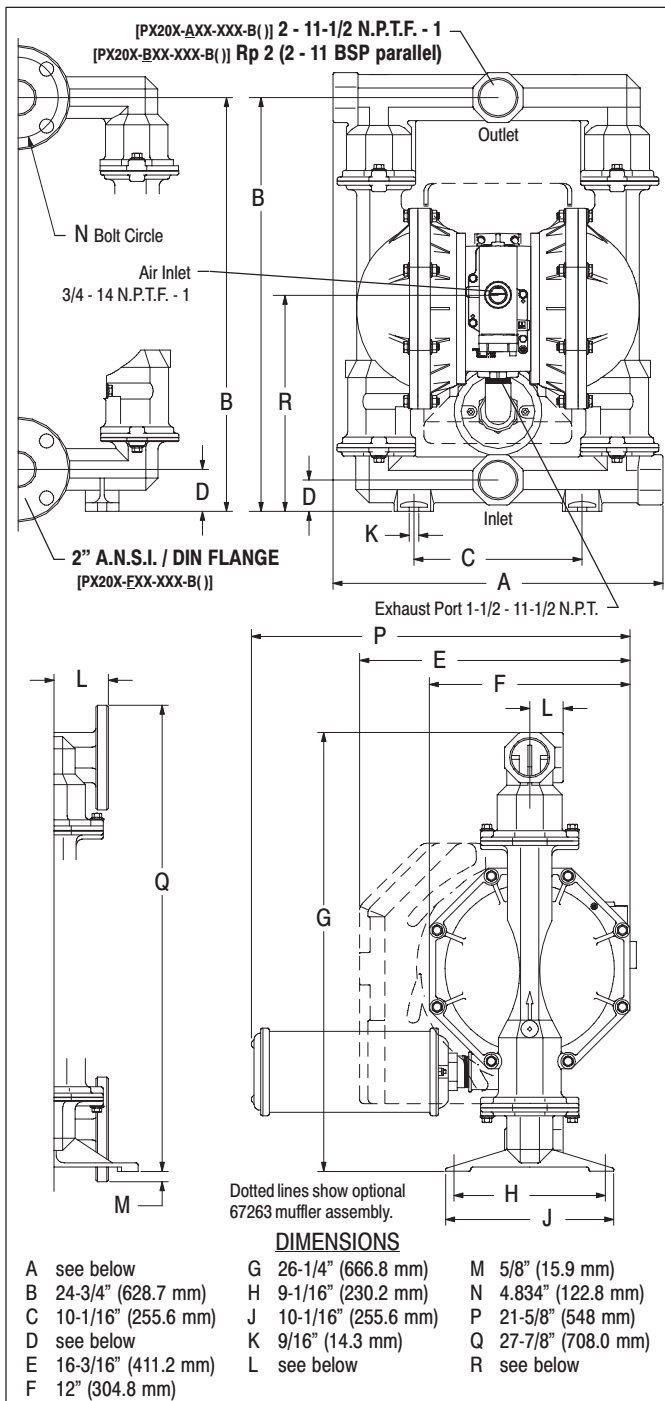

SPECIFICATIONS

CONSTRUCTION

Model Series	PD20A-X-X-B / PD20S-X-X-B
	PE20A-X-X-B() / PE20S-X-X-B()
Pump Type	Metallic, Air Operated, Double Diaphragm
Ratio	1:1
Material Inlet / Outlet (female)	
PX20X- <u>A</u> XX-XXX-B()	2 - 11-1/2 N.P.T.F. - 1
PX20X- <u>B</u> XX-XXX-B()	Rp 2 (2 - 11 BSP parallel)
PX20X- <u>F</u> XX-XXX-B()	2" A.N.S.I. / DIN Flange
Air Inlet (female)	3/4 - 14 N.P.T.F. - 1
Air Exhaust (female)	1-1/2 - 11-1/2 N.P.T.
Weight	
PX20A- <u>X</u> A-XXX-B()	91.4 lbs (41.5 kgs)
PX20A- <u>X</u> C-XXX-B()	147.4 lbs (66.9 kgs)
PX20A- <u>A</u> H-XXX-B(), -BHX	155.0 lbs (70.3 kgs)
PX20A- <u>A</u> S-XXX-B(), -BSX	149.8 lbs (68.0 kgs)
PX20A- <u>F</u> H-XXX-B(), -FSX	162.2 lbs (73.6 kgs)
(add 28.9 lbs [13.1 kgs] for stainless steel air motor section)	
Air Section Service Kit	637421
Fluid Section Service Kit	637309-XX
Major Air Valve Assembly	637374-X

PX20X-XXX-X -B()

637309 -

Diaphragm Material
Ball Material

EXAMPLE: Model # PD20A-AAP-AAA-B
Fluid Section Service Kit is 637309-AA

PERFORMANCE

Air Inlet Pressure Range	20 - 120 p.s.i. (1.4 - 8.3 bar)
Maximum Material Inlet Pressure	10 p.s.i. (0.69 bar)
Fluid Pressure Range	20 - 120 p.s.i. (1.4 - 8.3 bar)
Maximum Flow Rate	172 g.p.m. (651 l.p.m.)
Displacement / Cycle @ 100 p.s.i.	1.4 gal. (5.3 lit.)
Maximum Particle Size	1/4" dia. (6.4 mm)
Maximum Temperature Limits (diaphragm / ball / seal material)	
E.P.R. / EPDM	-60° to 280° F (-51° to 138° C)
Hytrel®	-20° to 150° F (-29° to 66° C)
Nitrile	10° to 180° F (-12° to 82° C)
PVDF (Kynar®)	10° to 200° F (-12° to 93° C)
Santoprene®	-40° to 225° F (-40° to 107° C)
T.F.E. (Teflon®)	40° to 225° F (4° to 107° C)
Viton®	-40° to 350° F (-40° to 177° C)
Noise Level @ 70 p.s.i. - 60 c.p.m.①	85.0 db(A)②

① Tested with 67263 muffler assembly installed.

② The pump sound pressure level has been updated to an Equivalent Continuous Sound Level (L_{Aeq}) to meet the intent of ANSI S1. 13-1971, CAGI-PNEUROPS S5.1 using four microphone locations.

ACCESSORIES:

66312 Air Line Connection Kit
67263 Continuous Muffler
94117 Int. Muffler

	"A"	"D"	"L"	"R"	NOTE: Dimensions are shown in inches and (mm), supplied for reference only and are typically rounded up to the nearest 1/16 inch.
PX20X- <u>X</u> A-XXX-B()	19-3/4" (501.4 mm)	1-7/8" (47.6 mm)	2" (50.8 mm)	12-15/16" (328.6 mm)	
PX20X- <u>X</u> C-XXX-B()	19-3/4" (501.4 mm)	1-7/8" (47.6 mm)	2" (50.8 mm)	12-15/16" (328.6 mm)	
PX20X- <u>A</u> H-XXX-B(), -BHX	19-1/4" (488.7 mm)	2-1/2" (63.5 mm)	2-3/32" (53.0 mm)	13-9/16" (344.5 mm)	
PX20X- <u>A</u> S-XXX-B(), -BSX	19-1/4" (488.7 mm)	2-1/2" (63.5 mm)	2-3/32" (53.0 mm)	13-9/16" (344.5 mm)	
PX20X- <u>F</u> H-XXX-B(), -FSX	19-1/4" (488.7 mm)	2-1/2" (63.5 mm)	3-1/4" (82.6 mm)	13-9/16" (344.5 mm)	

PERFORMANCE CURVES

PD20X-XXX-XXX-B / PE20X-XXX-XXX-B() 2" METALLIC DIAPHRAGM PUMP

