

OPERATOR'S MANUAL

650784-X-B

INCLUDING: OPERATION, INSTALLATION & MAINTENANCE

650779-X-B, 650780-X, 650785-X

INCLUDE MANUALS:

650780-X, 650785-X: PD20X-X (97999-672)

650779-X-B, 650784-X-B: PD30X-X-B (97999-813)

POWDER PUMP

RELEASED: 12-10-98

REVISED: 12-2-05

(REV. P)

2"
650780-X, 650785-X

3"
650779-X-B, 650784-X-B



**READ THIS MANUAL CAREFULLY BEFORE INSTALLING,
OPERATING OR SERVICING THIS EQUIPMENT.**

It is the responsibility of the employer to place this information in the hands of the operator. Keep for future reference.

SERVICE KITS

637302 for pump air section repair (all models).
637309-AA for fluid section repair (models 650780-X and 650785-X).
637303-AA for fluid section repair (models 650779-X-B and 650784-X-B).
7102 valve kit for repair of H254PS control valve.
118597-002 spool kit for repair of A212PD 4-way alpha valve.
104255 for repair of P29122-100 filter / regulator.

PUMP DATA

Models	650779-X-B	3" Aluminum (similar to PD30A-XAS-AAA-B)
	650780-X	2" Aluminum (similar to PD20A-XAS-AAA)
	650784-X-B	3" Stainless Steel (similar to PD30A-XSS-AAA-B)
	650785-X	2" Stainless Steel (similar to PD20A-XSS-AAA)
Pump Type	Dry powder Diaphragm Pump	
Specific Application	For pumping powders up to 50 lbs. / ft ³	
Wetted End Material		
	650779-X-B and 650780-X	Aluminum
	650784-X-B and 650785-X	Stainless Steel
Weight	650779-X-B (3")	121 lbs (54.9 kgs)
	650780-X (2")	72 lbs (32.7 kgs)
	650784-X-B (3")	211 lbs (95.7 kgs)
	650785-X (2")	162 lbs (73.5 kgs)
Maximum Air Inlet Pressure	50 p.s.i. (3.4 bar)	
Pump Ratio	1:1	
Maximum Fluidizing Pressure	100 p.s.i. (6.9 bar)	
Maximum Particle Size		
	650780-X and 650785-X (2")	1/4" (6.35 mm)
	650779-X-B and 650784-X-B (3")	3/8 (9.5 mm)
Maximum Temperature Limits	10° to 200° F (-12° to 93° C)	
Accessory Available	67183-1 Suction Probe Ass'y	
Noise Level @ 70 p.s.i., 50 c.p.m.	83.0 db(A)	

Tested with 94085 muffler assembly installed. The pump sound pressure levels published here have been updated to an Equivalent Continuous Sound Level (L_{Aeq}) to meet the intent of ANSI S1.13-1971, CAGI-PNEUROP S5.1 using four microphone locations.

GENERAL DESCRIPTION

This diaphragm pump was developed to address the unique problems associated with pumping of dry powders, which can "pack out" inside pump fluid chambers if not kept in a semi-fluid state.

This system incorporates the use of special valves to introduce air or inert gas* into the fluid chambers simultaneously to a pumping cycle in a timed sequence which keeps the powder in a fluidized state during the transfer process.

THEORY OF OPERATION

Refer to page 3 for view of major components (Ref. Ltr)

The main air distribution valve (B) is a double pilot actuated four way valve. It is a slave to the pump major air valve.

The distribution valve recognizes the signal from two pump major air valve (D) ports (air dumps). These signals are converted into alternating output pressure distributions which are injected into the fluid chambers during the pumping cycle to fluidize the powder as the diaphragm moves through the discharge stroke.

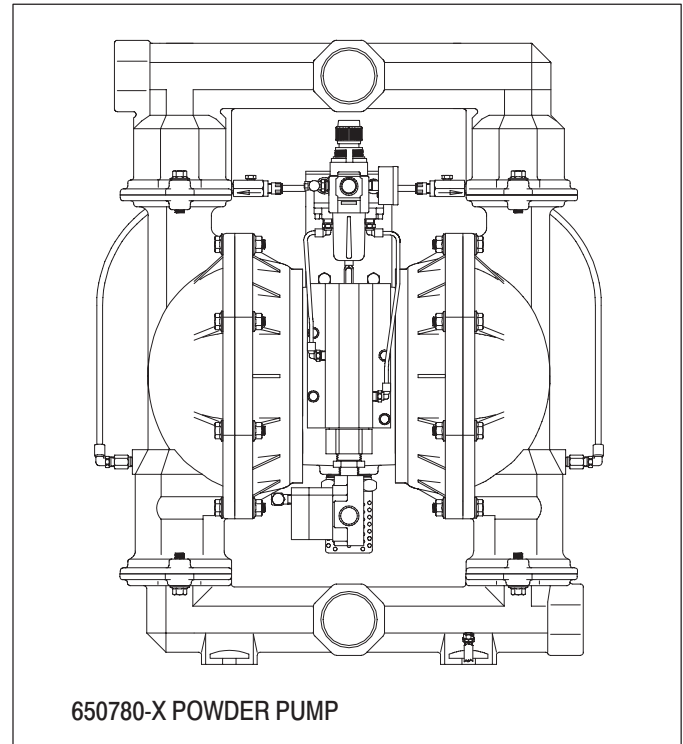

650780-X POWDER PUMP

The flow of air supplied to the fluid chamber is controlled by the filter / regulator. Under normal operating conditions, this is the primary control.

When air is supplied to the filter / regulator (A), the distribution valve directs the flow of air into the fluid chamber that will dispense first for 3 to 8 seconds. The time delay then supplies the start signal to open the main pump air supply valve. When the pump diaphragm reaches the end of the discharge stroke, it reverses direction. The distribution valve then shifts and shuts off the fluidizing air to the first fluid chamber as it applies a burst of air to the second fluid chamber and fluidizes the powder in the second chamber.

The air induction orifice (H) increases the air velocity prior to injection point because of the orifice and it prevents clogging of the injector feed line.

Note: The restart valve (G) is a bleed valve which will stop the pump and then restart the pump by re-initiating the time delay cycle.

* NOTE: Use of other gases: Using only a gas to operate a 2" or 3" pump can be rather expensive because of the high volume needed. Separate air / gas inputs allow the fluidizing feature of this pump to utilize special inert gas such as Nitrogen or Argon (air), if necessary, and still allow use of standard compressed shop air for the pumping function.

The ability to introduce special gas also means special materials could be injected thru the fluidization lines. Applications may include such materials as colorants, foaming agents, additives, neutralizers, etc.

INGERSOLL RAND COMPANY LTD
P.O. BOX 151 • ONE ARO CENTER • BRYAN, OHIO 43506-0151

☎ (800) 276-4658 • FAX (800) 266-7016 ©2005 CCN 99762767

 **Ingersoll Rand**
Industrial Technologies

AIR AND LUBE REQUIREMENTS

⚠ WARNING **EXCESSIVE AIR PRESSURE.** Can cause pump and property damage. The pump air supply must be limited to 50 p.s.i.g. (3.4 bar) maximum inlet air pressure.

- The air supply line or hose to the pump should be adequately sized to carry a sufficient volume of air to the pump. The material inlet supply tubing should not be too small or restrictive, which will inhibit material flow. The outlet material volume is governed not only by the air supply, but also by the material volume available at the inlet.
- Air supply provided should be filtered to provide clean, dry air. A filter capable of filtering out particles larger than 40 microns should be used on the air supply. There is no lubrication required other than the “O” ring lubricant which is applied during assembly or repair.
- If lubricated air is present, make sure that it is compatible with the Nitrile “O” rings in the air motor section of the pump.
- NOTE: When using air for powder fluidization, make sure it is filtered and very dry.

INSTALLATION

⚠ WARNING **THE PUMPING SYSTEM MUST BE GROUNDED TO PREVENT STATIC DISCHARGE. THIS INCLUDES THE PUMP AND ALL INPUT AND OUTPUT SUPPLY LINES AND RELATED SYSTEM DEVICES AND ACCESSORIES. FAILURE TO DO SO CAN RESULT IN EXPLOSION AND SERIOUS PERSONAL INJURY.**

SYSTEM GROUNDING:

- Consult local building codes and electrical codes for specific requirements.
- Must comply with all applicable Local and National codes for such applications.
- Grounding is accomplished through the ground lug and strap provided on the pump. Keep the grounding strap as short as possible.
- Safe operating conditions are the responsibility of the installer and operator.
- Secure diaphragm pump legs to a suitable surface to avoid damage by excessive vibration.

OPERATING INSTRUCTIONS

START-UP

NOTE: PRIOR TO START-UP, MAKE SURE THE GROUNDING INSTRUCTIONS WERE FOLLOWED.

1. Connect air supply to (F) main air supply control valve (30 - 40 p.s.i.).
2. Turn the air on.
3. Attach air (or gas) to (A) filter / regulator. CAUTION: Do not apply excessive Fluidizing Gas* Pressure (refer to note on page 1).
4. At (A), turn on air (or inert gas) supply. There will be a 3 to 8 second time delay, during which the pump will be fluidizing any powder left in the pump from an earlier dispense. This time delay will occur on all start-ups.

OPERATION AND ADJUSTMENT

NOTE: Powder type materials can vary in flow-ability and the same settings may not work universally. Factors such as density and humidity can require changing the mixture of flow rate and fluidization air and some experimenting should be expected.

IMPORTANT: DO NOT TURN FILTER / REGULATOR (A) OFF.

Positive air (or gas) pressure must be supplied to the filter / regulator to allow the pump to function. Powder will accumulate in the fluid caps if the pump is not al-

lowed to expel excess material before the pump shuts down. Restart can compress some powders to a solid that may cause the pump to fail. The pump should cycle until most of the powder has been purged before it is shut down.

Calibration procedure on initial start-up:

NOTE: Once these parameters are established for your specific application, they should not need to be changed.

- a) Turn the flow and pressure on the (A) filter / regulator all the way up.
- b) Slowly decrease pressure and flow until pump begins to labor (work harder).
- c) Increase pressure and flow back to a point where the pump begins to run smoothly. This will optimize the air-to-powder mix and will help to establish the most efficient working parameters.

If the pump should begin to cycle slowly (bog down), the powder can be purged by depressing restart button. This will stop the pump and restart the aeration cycle and allow time to increase air flow to the aeration ports for proper material movement.

IMPORTANT

SHUT DOWN PROCEDURE - TO HELP PREVENT PACK-OUT

It is good operating practice to dry cycle the pump 5 - 10 seconds at the end of each dispense cycle. This can be accomplished by closing off the powder source at the suction of the pump or pull wand from material. This will help clear the pump chambers of any residual powder.

NOTICE: Failure to insure proper fluidization can result in internal parts breakage and pump failure.

MAINTENANCE

Refer to the part views and descriptions as provided in the standard manual for parts identification and Service Kit information.

- Keep good records of service activity and include pump in preventive maintenance program.
- Certain ARO “Smart Parts” are indicated which should be available for fast repair and reduction of down time.
- Service kits are divided to service two separate diaphragm pump functions: 1. AIR SECTION, 2. FLUID SECTION. The FLUID SECTION is divided further to match typical part MATERIAL OPTIONS.
- Provide a clean work surface to protect sensitive internal moving parts from contamination from dirt and foreign matter during service disassembly and reassembly.

SCHEMATIC CIRCUIT

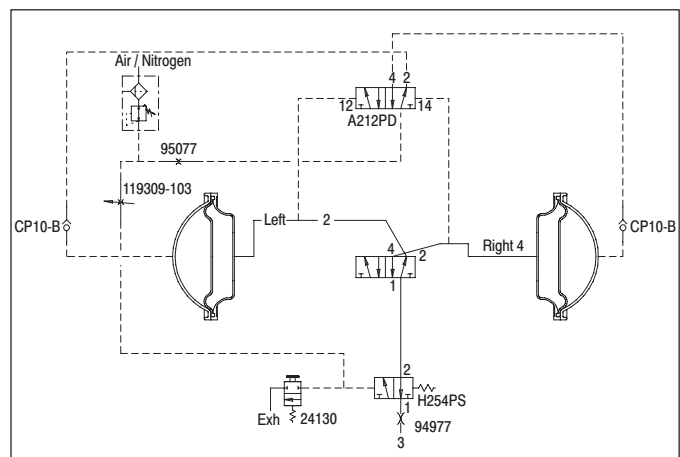

PARTS LIST / POWDER PUMP

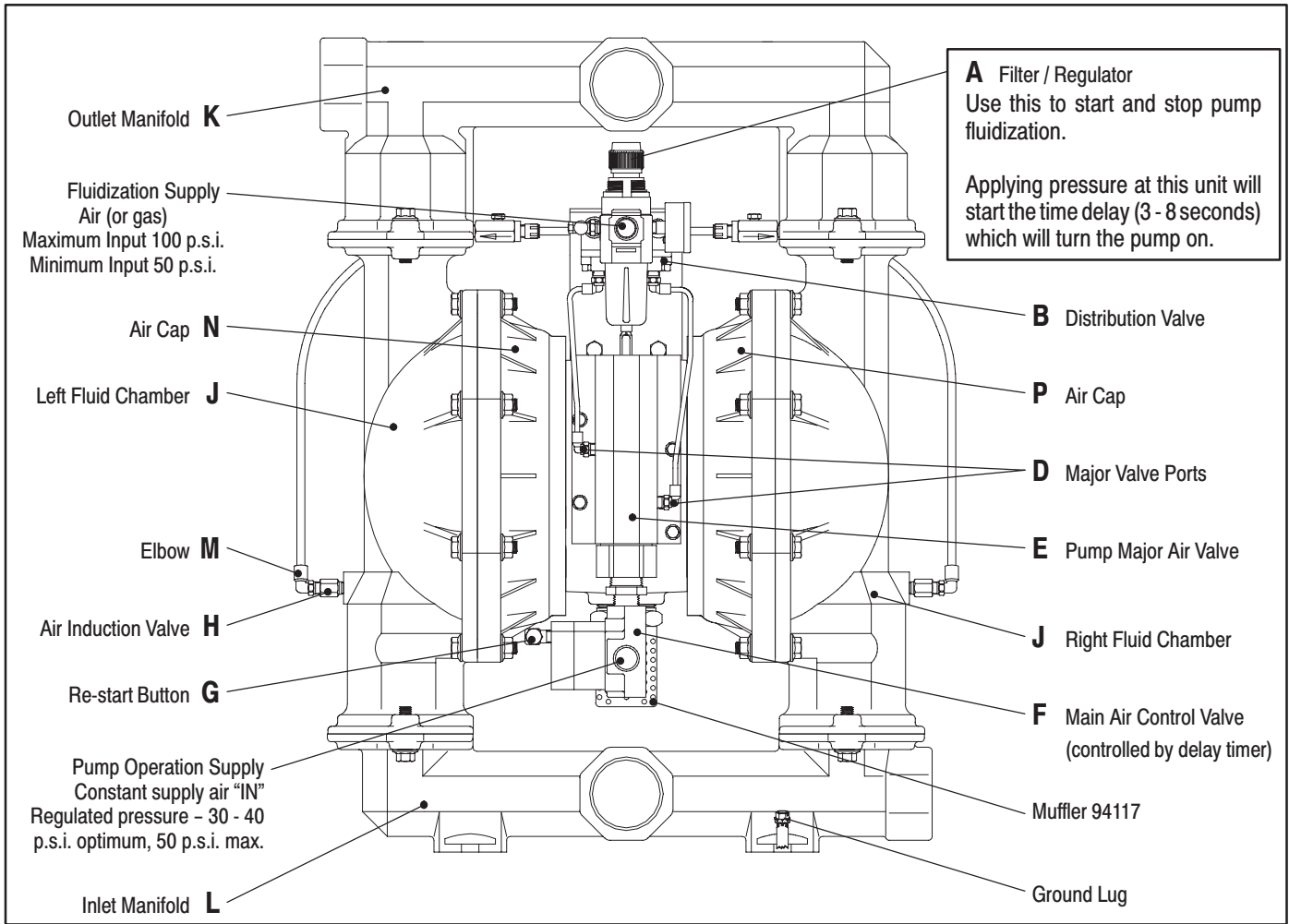

AIR CONTROL MAJOR COMPONENTS

Item	Description	Qty	Part No.
A	Piggyback Filter / Regulator	(1)	P29122-100
B	Alpha Valve, 4-Way	(1)	A212PD
D	Pilot Input Pickups (elbow)	(4)	59756-4
E	Major Air Valve Body	(1)	94811
F	Control Valve	(1)	H254PS
G	Re-fluidization Valve	(1)	24130
H	Air Induction - Orifice	(2)	94817
J	Fluid Chamber 2" Aluminum (model 650780-X)	(2)	94769
	2" Stainless Steel (model 650785-X)	(2)	95556
	3" Aluminum (model 650779-X-B)	(2)	94768
	3" Stainless Steel (model 650784-X-B)	(2)	94815
K	Outlet Manifold 2" N.P.T.F. Aluminum (model 650780)	(1)	94767
	2" B.S.P. Aluminum (model 650780-1)	(1)	94767-2
	2" N.P.T.F. Stainless Steel (model 650785)	(1)	95536-1
	2" B.S.P. Stainless Steel (model 650785-1)	(1)	95536-2
	3" N.P.T.F. Aluminum (model 650779-B)	(1)	94766
	3" B.S.P. Aluminum (model 650779-1-B)	(1)	94766-2
	3" N.P.T.F. Stainless Steel (model 650784-B)	(1)	94818
3" B.S.P. Stainless Steel (model 650784-1-B)	(1)	94818-2	
L	Inlet Manifold 2" N.P.T.F. Aluminum (model 650780)	(1)	94911
	2" B.S.P. Aluminum (model 650780-1)	(1)	94911-2

Item	Description	Qty	Part No.
	2" N.P.T.F. Stainless Steel (model 650785)	(1)	95537-1
	2" B.S.P. Stainless Steel (model 650785-1)	(1)	95537-2
	3" N.P.T.F. Aluminum (model 650779-B)	(1)	94913
	3" B.S.P. Aluminum (model 650779-1-B)	(1)	94913-2
	3" N.P.T.F. Stainless Steel (model 650784-B)	(1)	94216-1
	3" B.S.P. Stainless Steel (model 650784-1-B)	(1)	94216-2
M	Elbow (1/4" o.d. tube x 1/8 - 27 N.P.T.)	(2)	59756-56
N	Air Cap (2" - models 650780-X and 650785-X)	(1)	94324-4
	(3" - models 650779-X-B and 650784-X-B)	(1)	94030-4
P	Air Cap (2" - models 650780-X and 650785-X)	(1)	94324-5
	(3" - models 650779-X-B and 650784-X-B)	(1)	94030-5
5	Back-Up Washer (model 650780-X)	(2)	96503
	(model 650785-X)	(2)	94357-2
	(model 650779-X-B)	(2)	94831-2
	(model 650784-X-B)	(2)	94831-2
6	Fluid Side Washer (model 650780-X)	(2)	96503
	(model 650785-X)	(2)	94357-2
	(model 650779-X-B)	(2)	94803
	(model 650784-X-B)	(2)	94803
32	Leg (models 650784-X-B only)	(2)	94703-2
103	Bushing (bronze)(not shown)	(1)	95955

⚡ Item numbers refer to "Part's List" in PD20X-X (PN 97999-672) and PD30X-X-B (PN 97999-813) Operator's Manuals.

PARTS LIST / POWDER PUMP AIR CONTROL SECTION

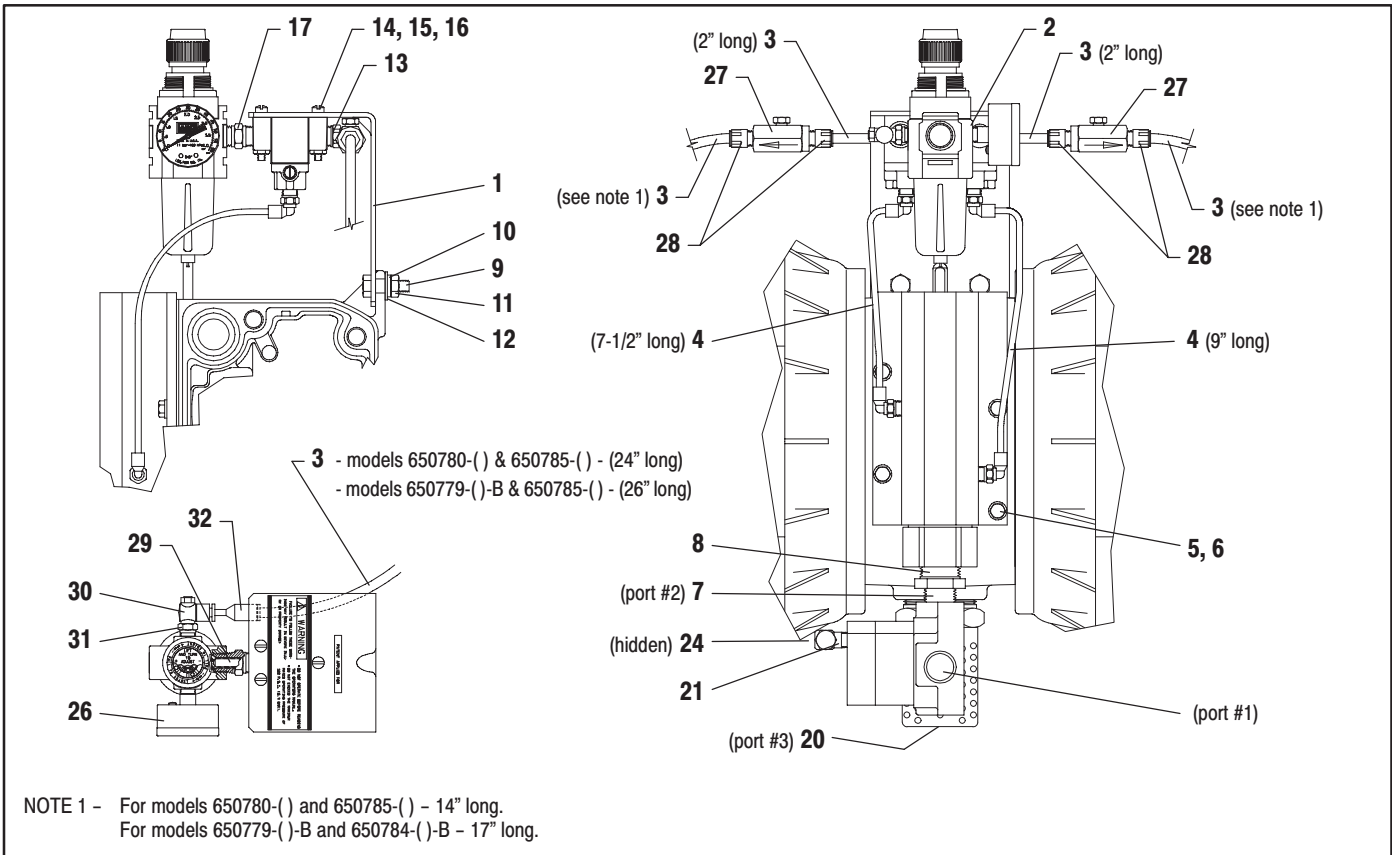

AIR CONTROL MAJOR HARDWARE ITEMS

Item	Description (size)	Qty	Part No.
1	Pump Bracket	(1)	95174
2	Plug (1/4 - 18 N.P.T.)	(3)	Y17-51-N
■ 3	Tube (1/4" o.d.)		59675-XXX-X
※※ 4	Tube (5/32" o.d.)		94981-XXX-X
5	Cap Screw (M6 - 1 x 16 mm)	(4)	96720081
6	Lock Washer (1/4")	(4)	Y14-416-T
7	Nipple (1/2 - 14 N.P.T.F. - 1 x 1-1/8")	(1)	Y27-4-C
8	Reducing Bushing (3/4 x 1/2 N.P.T.)	(1)	Y45-9-C
9	Screw (5/16" - 18 x 1")	(2)	Y6-55-C
10	Lock Washer (5/16")	(2)	Y117-516
11	Nut (5/16" - 18)	(2)	Y12-5-C
12	Washer (5/16" i.d. x 3/4" o.d.)	(2)	Y13-4-C
13	Elbow (1/4" o.d. tube x 1/4 - 18 N.P.T.F. - 1)	(2)	59756-156
14	Screw (#10 - 24 x 1-1/4")	(3)	Y19-113-C
15	Nut (#10 - 24)	(3)	Y22-10-C
16	Washer (#10)	(3)	Y14-10-C

Item	Description (size)	Qty	Part No.
17	Nipple (1/4 - 18 N.P.T.F. - 1)	(1)	1950
★ 18	Ground Screw (1/4" - 14 x 1/2")	(1)	Y334-104-C
★ 19	Ground Cable	(1)	94829
20	Pipe Plug w / 0.078" orifice (1/2 - 14 N.P.T.)	(1)	94977
21	Adapter (1/8 - 27 P.T.F.)	(1)	94812
24	Connector (1/4" o.d. tube x 1/8 - 27 N.P.T.)	(1)	59474-56
★ 25	Air Line Connection Kit	(1)	67223
26	Gauge (0 - 160 p.s.i. / 0 - 11 bar)	(1)	29850
27	Check Valve (1/8 - 27 N.P.T.F.)	(2)	CP10-B
28	Connector (1/4" o.d. tube x 1/8 - 27 N.P.T.)	(4)	59474-56
29	Restrictor	(1)	95077
30	Flow Control (1/4" o.d. tube x #10 - 32)	(1)	119309-103
31	Adapter (1/8 - 27 N.P.T.F. male x #10 - 32 female)	(1)	59629
32	Reducer (1/4" o.d. tube x 5/32" o.d. tube)	(1)	59765-4

★ Parts not shown.
 ■ Bulk Tubing (1/4" o.d. x 100' long).
 ※※ Bulk Tubing (5/32" o.d. x 100' long).

TROUBLE SHOOTING

Low output volume, erratic flow or no flow.

- Check air supply.
- Check for plugged outlet hose.
- Check for kinked (restrictive) outlet material hose.
- Check for kinked (restrictive) or collapsed inlet material hose.
- Suction hose must be a non-collapsing type, conductive and capa-

ble of pulling a high vacuum (up to 30" mercury).

- Check all joints on the inlet manifolds and suction connections. Connections must be air tight.
- Inspect the pump for solid objects lodged in the diaphragm chamber or the seat area.