

OPERATOR'S MANUAL

650719-C

INCLUDING: OPERATION, INSTALLATION & MAINTENANCE

RELEASED: 8-11-03
REVISED: 3-5-05
(REV. 04)

2" DIAPHRAGM PUMP U.L. LISTED, 1:1 RATIO (METALLIC)



**READ THIS MANUAL CAREFULLY BEFORE INSTALLING,
OPERATING OR SERVICING THIS EQUIPMENT.**

It is the responsibility of the employer to place this information in the hands of the operator. Keep for future reference.

SERVICE KITS

637118-C for air section repair (see page 6).
637138-63 for fluid section repair (see page 4).

PUMP DATA

Models	650719-C
Application	Diesel Fuel, Kerosene, Aviation Fuel, Fuel Oil and Unleaded Fuel
Pump Type	U.L. Listed Metallic Air Operated Double Diaphragm for use with Petro- leum Product Dispensing Systems.
Material	see "Model Description Chart"
Weight	57.9 lbs (26.3 kg)
Maximum Air Inlet Pressure	50 p.s.i. (3.5 bar)
Maximum Outlet Pressure	50 p.s.i. (3.5 bar)
Maximum Flow Rate (flooded inlet) ..	75 g.p.m. (284 l.p.m.)
Maximum Particle Size	1/4" dia.
Maximum Temperature Limits ..	10° to 180° F (-12° to 82° C)
Dimensional Data	see page 8

GENERAL DESCRIPTION

The ARO U.L. listed pump for pumping petroleum products offers high volume delivery at low air pressures and easy self-priming. This model is designed specifically for the transfer, bulk un-loading or fueling applications. It includes a pressure relief valve (per U.L. Specification 79) which restricts the fluid outlet pressure to under 50 p.s.i. (3.5 bar). The relief valve can be plumbed to return the bleed off fuel to the storage container.

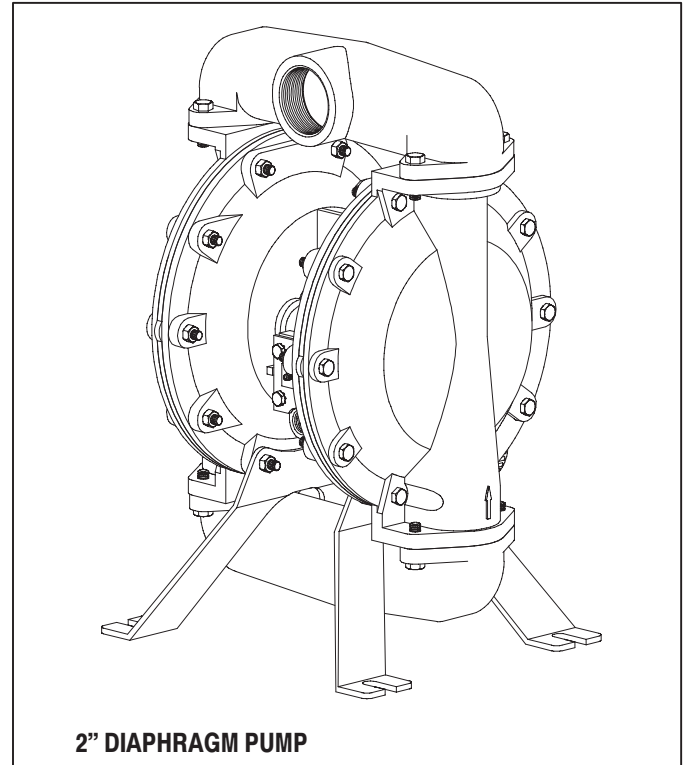

2" DIAPHRAGM PUMP

MODEL DESCRIPTION CHART

65071 X - C

DIAPHRAGM MATERIAL

9 - Viton®

CENTER BODY MATERIAL, THREADS

Aluminum, 2 - 11-1/2 N.P.T.F. - 1

FLUID CAP / MANIFOLD MATERIAL, INLET / OUTLET

Aluminum, Single (Steel Hardware)

SEAT MATERIAL

P.V.D.F. (Kynar®)

BALL MATERIAL

Acetal

OPERATING AND SAFETY PRECAUTIONS

READ, UNDERSTAND, AND FOLLOW THIS INFORMATION TO AVOID INJURY AND PROPERTY DAMAGE.



⚠ WARNING EXCESSIVE AIR PRESSURE. Can cause personal injury, pump damage or property damage.

- Do not exceed the maximum inlet air pressure as stated on the pump model plate.
- Be sure material hoses and other components are able to withstand fluid pressures developed by this pump. Check all hoses for damage or wear. Be certain dispensing device is clean and in proper working condition.

⚠ WARNING STATIC SPARK. Can cause explosion resulting in severe injury or death. Ground pump and pumping system.

- Sparks can ignite flammable material and vapors.
- The pumping system and object being sprayed must be grounded when it is pumping, flushing, recirculating or spraying flammable materials such as paints, solvents, lacquers, etc. or used in a location where surrounding atmosphere is conducive to spontaneous combustion. Ground the dispensing valve or device, containers, hoses and any object to which material is being pumped.
- Use the pump grounding screw terminal provided. Use ARO part no. 66885-1 ground kit or connect a suitable ground wire (12 ga. min.) to a good earth ground source.
- Secure pump, connections and all contact points to avoid vibration and generation of contact or static spark.
- Consult local building codes and electrical codes for specific grounding requirements.
- After grounding, periodically verify continuity of electrical path to ground. Test with an ohmmeter from each component (e.g., hoses, pump, clamps, container, spray gun, etc.) to ground to insure continuity. Ohmmeter should show 0.1 ohms or less.
- Submerge the outlet hose end, dispensing valve or device in the material being dispensed if possible. (Avoid free streaming of material being dispensed.)
- Use hoses incorporating a static wire.
- Use proper ventilation.
- Keep inflammables away from heat, open flames and sparks.
- Keep containers closed when not in use.

⚠ WARNING Pump exhaust may contain contaminants. Can cause severe injury. Pipe exhaust away from work area and personnel.

- In the event of a diaphragm rupture material can be forced out of the air exhaust muffler.
- Pipe the exhaust to a safe remote location when pumping hazardous or inflammable materials.
- Use a grounded 3/4" minimum i.d. hose between the pump and the muffler.

⚠ WARNING HAZARDOUS PRESSURE. Can result in serious injury or property damage. Do not service or clean pump, hoses or dispensing valve while the system is pressurized.

- Disconnect air supply line and relieve pressure from the system by opening dispensing valve or device and / or carefully and slowly loosening and removing outlet hose or piping from pump.

⚠ WARNING HAZARDOUS MATERIALS. Can cause serious injury or property damage. Do not attempt to return a pump to the factory or service center that contains hazardous material. Safe handling practices must comply with local and national laws and safety code requirements.

- Obtain Material Safety Data Sheets on all materials from the supplier for proper handling instructions.

⚠ WARNING EXPLOSION HAZARD. Models containing aluminum wetted parts cannot be used with III.-Trichloroethane, Methylene Chloride or other Halogenated Hydrocarbon solvents which may react and explode.

- Check pump motor section, fluid caps, manifolds and all wetted parts to assure compatibility before using with solvents of this type.

⚠ CAUTION Verify the chemical compatibility of the pump wetted parts and the substance being pumped, flushed or recirculated. Chemical compatibility may change with temperature and concentration of the chemical(s) within the substances being pumped, flushed or circulated. For specific fluid compatibility, consult the chemical manufacturer.

⚠ CAUTION Maximum temperatures are based on mechanical stress only. Certain chemicals will significantly reduce maximum safe operating temperature. Consult the chemical manufacturer for chemical compatibility and temperature limits. Refer to PUMP DATA on page 1 of this manual.

⚠ CAUTION Be certain all operators of this equipment have been trained for safe working practices, understand it's limitations, and wear safety goggles / equipment when required.

⚠ CAUTION Do not use the pump for the structural support of the piping system. Be certain the system components are properly supported to prevent stress on the pump parts.

- Suction and discharge connections should be flexible connections (such as hose), not rigid piped, and should be compatible with the substance being pumped.

⚠ CAUTION Prevent unnecessary damage to the pump. Do not allow pump to operate when out of material for long periods of time.

- Disconnect air line from pump when system sits idle for long periods of time.

⚠ CAUTION Use only genuine ARO replacement parts to assure compatible pressure rating and longest service life.

NOTICE Replacement warning labels are available upon request: "Static Spark pn \ 93616-1 & Diaphragm Rupture pn \ 93122."

⚠ WARNING = Hazards or unsafe practices which could result in severe personal injury, death or substantial property damage.

⚠ CAUTION = Hazards or unsafe practices which could result in minor personal injury, product or property damage.

NOTICE = Important installation, operation or maintenance information.

AIR AND LUBE REQUIREMENTS

⚠ WARNING **EXCESSIVE AIR PRESSURE.** Can cause pump and property damage. The air supply must be limited to 50 p.s.i.g. (3.4 bar) maximum inlet air pressure.

- The air supply line or hose to the pump should be adequately sized to carry a sufficient volume of air to the pump. The material inlet supply tube should not be too small or restrictive which will inhibit material flow. The outlet material volume is governed not only by the air supply but also by the material volume available at the inlet.
- Air supply provided should be filtered to provide clean dry air. A filter capable of filtering out particles larger than 50 microns should be used on the air supply. There is no lubrication required other than the “O” ring lubricant which is applied during assembly or repair.
- If lubricated air is present, make sure that it is compatible with the Nitrile “O” rings in the air motor section of the pump.

INSTALLATION

IMPORTANT

- Requirements for the installation are included in the Flammable and Combustible Liquids Code, NFPA No. 30, Automotive and Marine Service Station Code, NFPA No. 30A and the National Electric Code, ANSI / NFPA No. 70.
- A fluid return hose which is compatible with the fluid being pumped must be installed to the relief valve on the outlet manifold to return fluid back to the supply tank or pump inlet.
- The pump must be grounded to prevent static discharge. Grounding may be accomplished through the legs or to the ground lug provided on the pump.
- Notice that the material inlet / outlet manifolds may be removed and rotated 180° to facilitate various mounting applications.
- If the body of the pump must be rotated remove the end covers and manifolds and index it so the bolts line up properly. NOTE: The arrow on the end cap must always point upward for optimum performance.
- When the diaphragm pump is used in a force-feed situation it is recommended that a check valve be installed at the air inlet to keep material out of air line in the event of a diaphragm failure.
- Secure diaphragm pump legs to a suitable surface to insure against damage by excessive vibration.

OPERATING INSTRUCTIONS

- The pump should never be operated at pressures exceeding 50 p.s.i.g. (345 kPa) inlet air pressure. This pump is equipped with a pressure relief valve on the material outlet manifold which will open at 40 +/- 4 p.s.i. (2.76 bar) to relieve pressure increases in the outlet hoses / plumbing caused by thermal expansion or other external forces.
- Disconnect the air supply from the pump if it is to be inactive for a few hours.

MAINTENANCE

Refer to the part views and descriptions as provided on page 4 through 7 for parts identification and Service Kit information.

- Certain ARO “Smart Parts” are indicated which should be available for fast repair and reduction of down time.
- Service kits are divided to service two separate diaphragm pump functions: 1. AIR SECTION, 2. FLUID SECTION. The FLUID SECTION is divided further to match typical part MATERIAL OPTIONS.
- Provide a clean work surface to protect sensitive internal moving parts from contamination from dirt and foreign matter during service disassembly and reassembly.
- Keep good records of service activity and include pump in preventive maintenance program.
- Before disassembling, empty captured material in the outlet manifold by turning the pump upside down to drain material from the pump.

PARTS LIST / FLUID SECTION

FLUID SECTION SERVICE KITS

✓ KITS INCLUDE: (22) BALLS, (7) DIAPHRAGMS, plus "O" Ring items: 2, 3, 19 (refer to chart below) and 93706-1 Key-Lube® grease.

WETTED COMMON PARTS				
Item	Description (size)	Qty	Part No.	[Mtl]
	Fluid Section Service Kits		637138-63	
<input type="checkbox"/> 1	Rod	(1)	98720-1	[C]
✓ 2	"O" Ring (3/32" x 1" o.d.)	★ (1)	Y330-117	[B]
✓ 3	"O" Ring (1/16" x 3/4" o.d.)	(4)	Y327-16	[V]
5	Plate (air side)	(2)	92752	[C]
<input type="checkbox"/> 6	Plate (fluid side)	(2)	92752	[C]
✓ 7	Diaphragm	(2)	92755-3	[V]
9	Washer (0.630" i.d.)	(2)	93065	[SS]
14	Screw (5/8" - 18 x 1-1/2")	(2)	Y5-107-K	[C]
15	Fluid Cap	(2)	92750	[A]
16	Manifold (top with valve port)	(1)	93129	[A]
	Manifold (bottom)	(1)	92855	[A]
✓ 19	"O" Ring (1/8" x 2-3/4" o.d.)	(4)	Y327-230	[V]
21	Seat	(4)	92942	[K]
✓ 22	Ball (1-3/4" dia.)	(4)	92757-6	[D]
26	Bolt (3/8" - 16 x 1-1/4")	(8)	Y6-66-C	[C]
27	Bolt (5/16" - 18 x 2-1/4")	(4)	Y6-510-C	[C]
29	Nut (5/16" - 18)	(20)	Y12-5-C	[C]
32	Leg	(2)	92759	[C]
43	Ground Lug (see page 7)	(1)	93004	[Co]
59	Bolt (5/16" - 18 x 2")	(16)	93608	[C]
	Relief Valve (see page 5)	(1)	96333	[Br]

MATERIAL CODE	
[A]	Aluminum
[B]	Nitrile
[Br]	Brass
[C]	Carbon Steel
[Co]	Copper
[D]	Acetal
[K]	P.V.D.F. (Kynar)
[SS]	Stainless Steel
[V]	Viton

Service Note: Part no. 98930-T installation tool is available to aid assembly of items (1) and (2).

★ Service Note: Extra "O" rings are included in service kits to repair models built prior to Dec. 1989.

"Smart Parts", keep these items on hand in addition to the service kits for fast repair and reduction of down time.

FLUID SECTION DISASSEMBLY

1. Remove (16) top manifold(s).
2. Remove (22) balls, (19) "O" rings, (21) seats.
3. Remove (15) fluid caps.
4. Remove the (14) screws, (9) washers, (3) "O" rings, (6) plates, (7) diaphragms and (5) plates.
5. Remove (3) "O" rings.

NOTE: Do not scratch or mar the surface of (1) diaphragm rod.

FLUID SECTION REASSEMBLY

- Reassemble in reverse order.
- Clean and inspect all parts. Replace worn or damaged parts with new parts as required.
- Lubricate (1) diaphragm rod and (2) "O" ring with Key-Lube grease.
- Use ARO pn / 98930-T bullet (installation tool) to aid in installation of (2) "O" ring on (1) diaphragm rod.
- Be certain (7) diaphragms align properly with (15) fluid caps before making final torque adjustments on bolt and nuts to avoid twisting the diaphragm.
- Re-check torque settings after pump has been re-started and run a while.

PARTS LIST / FLUID SECTION

COLOR CODE		
MATERIAL	DIAPHRAGM COLOR	BALL COLOR
ACETAL	N / A	Orange
VITON	Yellow (-)	N / A
	(-) Stripe	

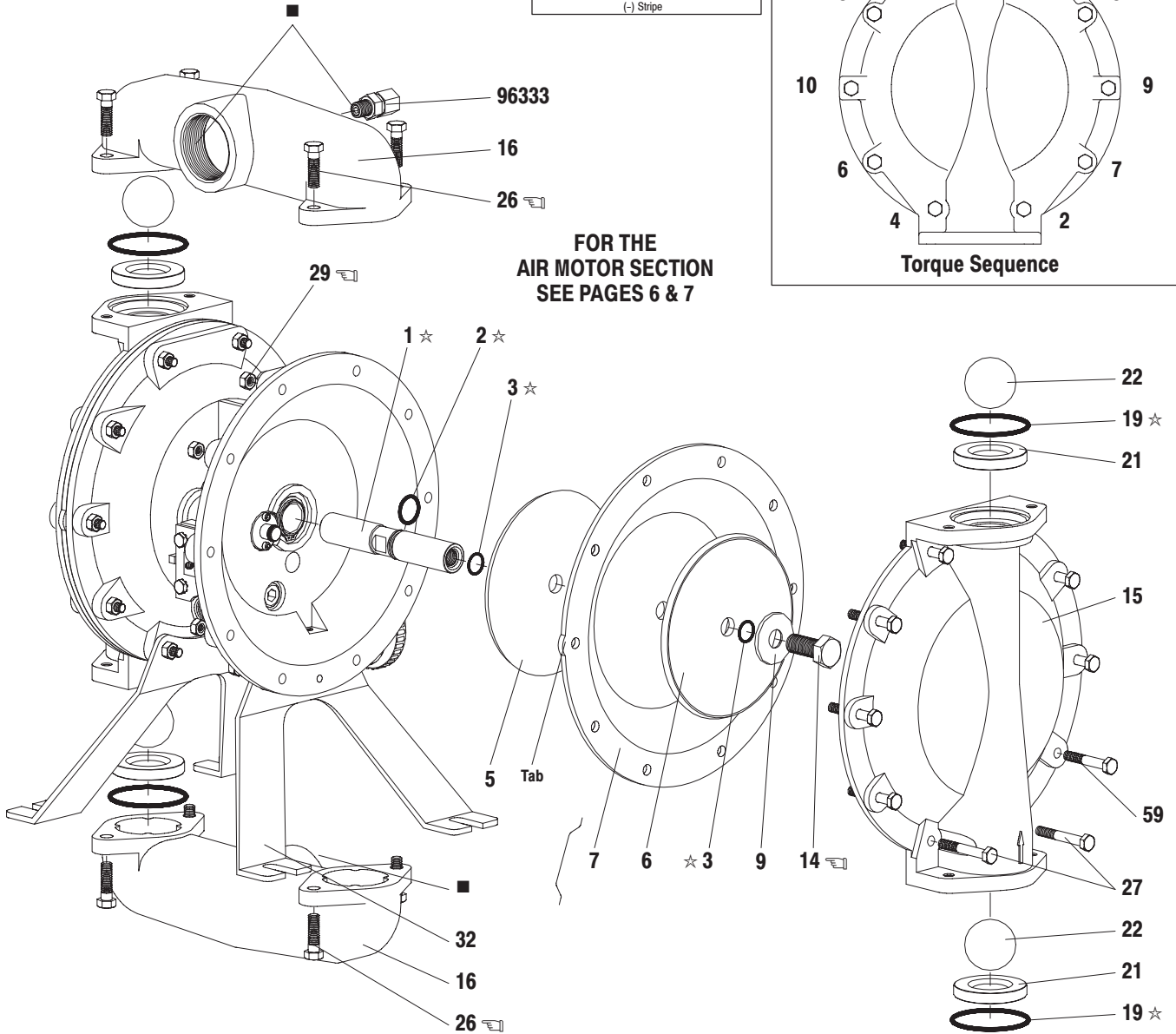
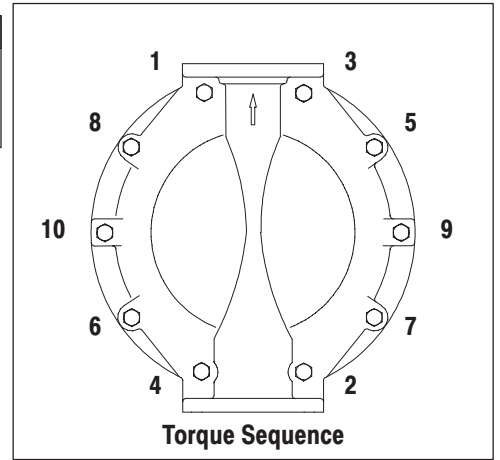

FOR THE
AIR MOTOR SECTION
SEE PAGES 6 & 7

○ NOTE: Radius edge of parts (5 and 6) is against diaphragm.

TORQUE REQUIREMENTS

NOTE: DO NOT OVERTIGHTEN FASTENERS
 (14) Diaphragm bolt 65 - 70 ft lbs (88.1 - 94.9 Nm),
 apply Loctite 271 to threads.
 (26, 29) Fluid cap / manifold nuts and bolts 120 - 140 in. lbs (13.6 - 15.8 Nm).

LUBRICATION / SEALANTS

- ☆ Apply Key-Lube to all "O" rings, "U" Cups & mating parts.
- Apply gasoline-resistant pipe sealant to pipe threads.

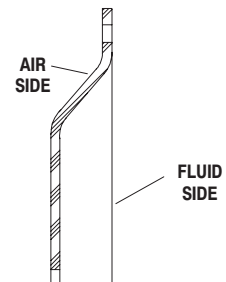

CROSS SECTION VIEW OF DIAPHRAGMS

Figure 1

PARTS LIST / AIR MOTOR SECTION

✓ Indicates parts included in 637118-C Air Section Service Kit.

Item	Description (size)	Qty	Part No.	[Mtl]
101	Motor Body (includes items 195)	(1)	93161	[A]
□ 102	"O" Ring (0.07" x 1.25" o.d.)	(2)	92960	[B]
□ 103	Sleeve	(1)	94528	[D]
✓ 104	Retaining Ring, TruArc (1-5/32" i.d.)	(2)	Y145-26	[C]
105	Screw / Washer (1/4" - 20 x 5/8")	(8)	93860	[C]
106	Lock Washer (1/4")	(1)	Y14-416-T	[SS]
107	Plate	(2)	93707-1	[SS]
✓ 108	Gasket (with notch)	(1)	92878	[B/NY]
□ 109	Piston	(1)	92011	[D]
✓ 110	"U" Cup (3/16" x 1-3/8" o.d.)	(1)	Y186-51	[B]
□ 111	Spool	(1)	92005	[A]
112	Washer (1.556" o.d.)	(5)	92877	[Z]
✓ 113	"O" Ring (small) (1/8" x 1-1/4" o.d.)	(5)	Y325-214	[B]
✓ 114	"O" Ring (large) (3/32" x 1-9/16" o.d.)	(6)	Y325-126	[B]
□ 115	Spacer	(4)	92876	[Z]
□ 116	Spacer	(1)	92006	[Z]

Item	Description (size)	Qty	Part No.	[Mtl]
✓ 117	Gasket	(1)	92004	[B/NY]
118	Pilot Rod	(1)	93309-2	[C]
✓ 119	"O" Ring (1/8" x 3/4" o.d.)	(4)	93075	[U]
120	Spacer	(3)	115959	[Z]
121	Sleeve Bushing	(2)	98723-2	[Bz]
✓ 122	"O" Ring (3/32" x 9/16" o.d.)	(2)	94820	[U]
✓ 123	Screw (#8 - 32 x 3/8")	(4)	Y154-41	[C]
126	Pipe Plug (1/2 - 14 P.T.F. x 17/32")	(1)	Y227-5-L	[C]
127	Elbow (3/4 - 14 N.P.T. x 1-7/8")	(1)	Y43-5-C	[C]
128	Pipe Plug (1/8 - 27 P.T.F. x 1/4")	(1)	Y227-2-L	[C]
195	Button Head Screw (1/4" - 20 x 1/4")	(2)	94987	[SS]
196	Button Head Screw (1/4" - 20 x 3/8")	(1)	94987-1	[SS]
201	Muffler	(1)	93139	[P]
✓	Key-Lube "O" Ring Lubricant	(1)	93706-1	
	10 Pak of Key-Lube		637175	

□ "Smart Parts", keep these items on hand in addition to the Service Kits for fast repair and reduction of down time.

AIR MOTOR SECTION SERVICE

Service is divided into two parts - 1. Pilot Valve, 2. Major Valve.

GENERAL REASSEMBLY NOTES:

- Air Motor Section Service is continued from Fluid Section repair.
- Inspect and replace old parts with new parts as necessary. Look for deep scratches on metallic surfaces, and nicks or cuts in "O" rings.
- Take precautions to prevent cutting "O" rings upon installation.
- Lubricate "O" rings with Key-Lube grease.
- Do not over-tighten fasteners, refer to torque specification block on view.
- Re-torque fasteners following restart.

PILOT VALVE DISASSEMBLY

1. Remove (104) retaining ring.
2. Remove (123) screws and (122) "O" rings.
3. Remove (118) piston rod, (121) sleeve bushing, (119) "O" rings and (120) spacers from the (101) motor body.
4. Remove (103) sleeve and (102) "O" rings.

PILOT VALVE REASSEMBLY

1. Replace two (102) "O" rings if worn or damaged and reinstall (103) sleeve.
2. Install one of the (121) sleeve bushings, (119) "O" rings, (120) spacers and the remaining (121) bushing.
3. Carefully push (118) pilot rod into bushings etc. and retain on each end with the two (122) "O" rings, retain with (123) screws.
4. Replace (104) retaining rings.

MATERIAL CODE

[A] = Aluminum	[D] = Acetal	[U] = Polyurethane
[B] = Nitrile	[NY] = Nylon	[SS] = Stainless Steel
[Bz] = Bronze	[P] = Polypropylene	[Z] = Zinc
[C] = Carbon Steel		

MAJOR VALVE DISASSEMBLY

1. Remove (107) plate, (108) and (117) gaskets.
2. On the side opposite the air inlet, push on the inner diameter (111) spool. This will force the (109) piston out. Continue pushing the (111) spool and remove. Check for scratches and gouges.
3. Reach into the air section (exhaust side) and remove (116) spacer, (115) spacers, (113) "O" rings, (114) "O" rings, (112) washers, etc. Check for damaged "O" rings.

MAJOR VALVE REASSEMBLY

1. Replace (112) washer, (114) "O" ring and (113) "O" ring onto (115) spacer and insert etc.
NOTE: Be careful to orient spacer legs away from blocking internal ports.
2. Lubricate and carefully insert (111) spool.
3. Install (117) gasket and (107) plate.
4. Lubricate and install (110) packing cup and insert (109) piston into (air inlet side) cavity, the (110) packing cup lips should point outward.
5. Install (108) gasket and replace (107) plate.

PARTS LIST / AIR MOTOR SECTION

IMPORTANT
BE CERTAIN TO ORIENT (115) SPACER LEGS AWAY FROM BLOCKING INTERNAL PORTS WHEN REASSEMBLING AIR SECTION.

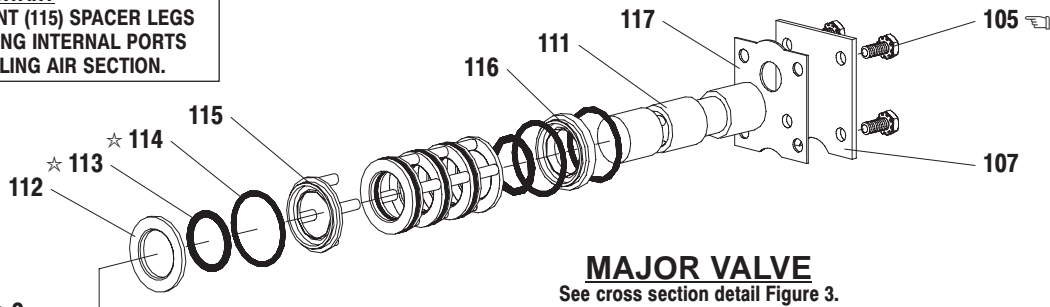
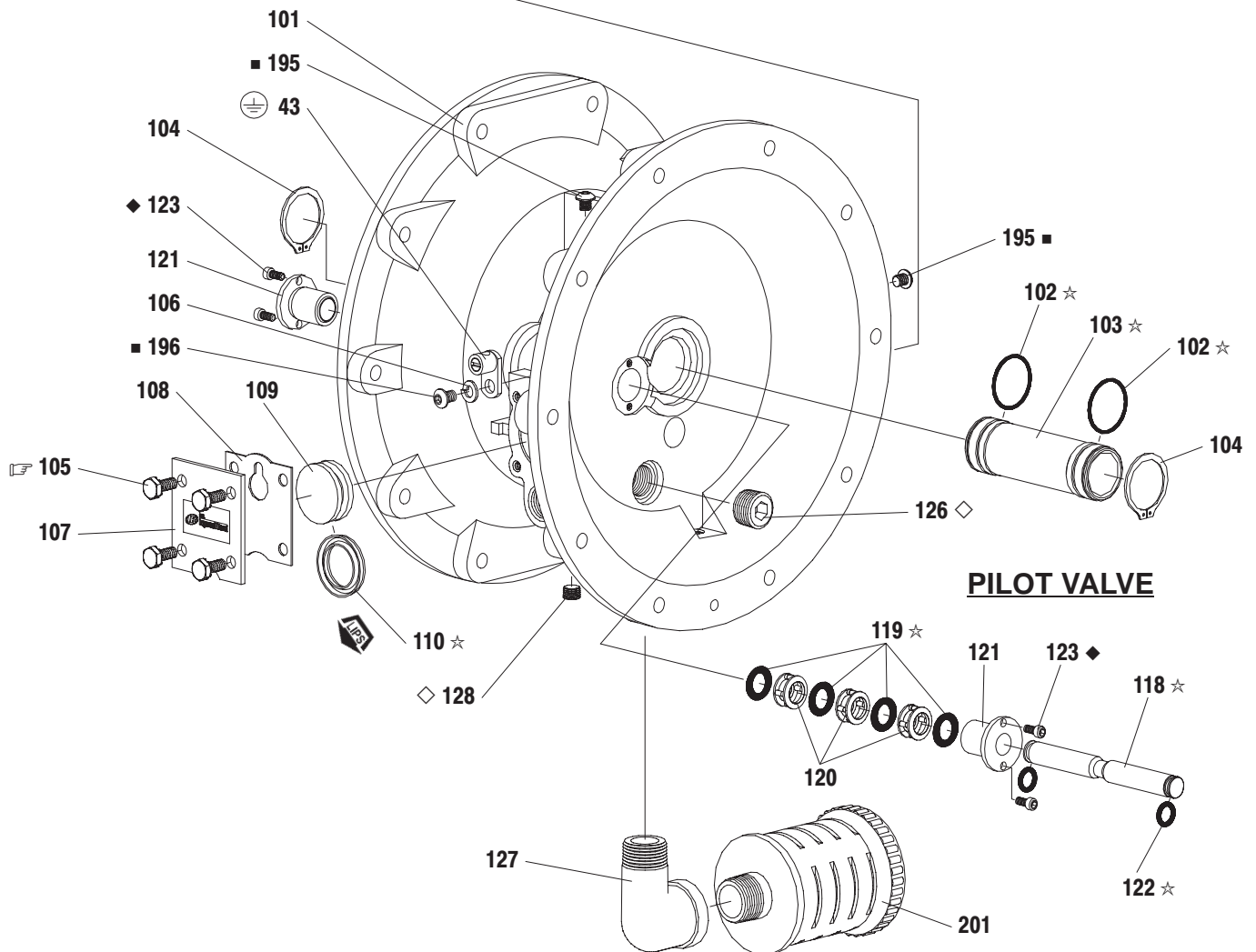
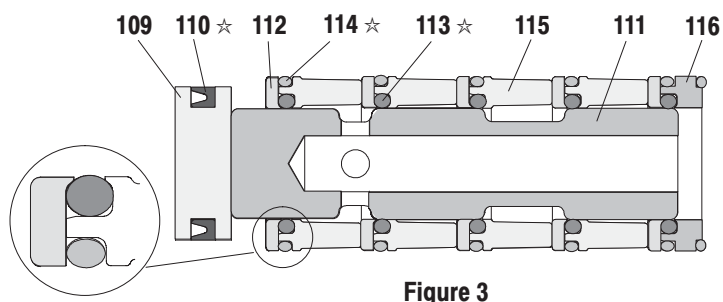

Figure 2



MAJOR VALVE CROSS SECTION DETAIL



TORQUE REQUIREMENTS
NOTE: DO NOT OVERTIGHTEN FASTENERS
(105) 40 - 50 in. lbs (4.5 - 5.6 Nm),
apply Loctite Nickel Antiseize to threads.

LUBRICATION / SEALANTS

- ☆ Apply Key-Lube to all "O" rings, "U" Cups & mating parts.
- ◆ Apply Loctite 271 to threads.
- ◇ Apply pipe sealant to threads.
- Apply Dri-Loc 204 to threads.

TROUBLE SHOOTING

Product discharged from exhaust outlet.

- Check for diaphragm rupture.
- Check tightness of diaphragm nut.

Air bubbles in product discharge.

- Check connections of suction plumbing.
- Check "O" rings between intake manifold and fluid caps.
- Check tightness of diaphragm nut.

Low output volume, erratic flow, or no flow.

- Check air supply.
- Check for plugged outlet hose.
- Check for kinked (restrictive) outlet material hose.
- Check for kinked (restrictive) or collapsed inlet material hose.
- Check for pump cavitation - suction pipe should be sized at least as large as the inlet thread diameter of the pump for proper flow if high viscosity fluids are being pumped. Suction hose must be a non-collapsing type, capable of pulling a high vacuum.
- Check all joints on the inlet manifolds and suction connections. These must be air tight.
- Inspect the pump for solid objects logged in the diaphragm chamber or the seat area.

DIMENSIONAL DATA

(Dimensions shown are for reference only, they are displayed in inches and millimeters (mm).)

