



Model: ALH 15

Technical Datasheet

24.10.2008

Weight 40.0Kg	
L.Hose 830.0 mm	
D.Hose 15.0 mm	
Dim.	mm
A	73.00
B	193.00
C	296.00
D	145.00
E	322.00
F	250.00
G	280.00
H	51.75
I	300.00
J	330.00
K	13.00
L	-
M	49.00
N	33.50
O	Barb Insert o20
P	68.50
Q	124.75

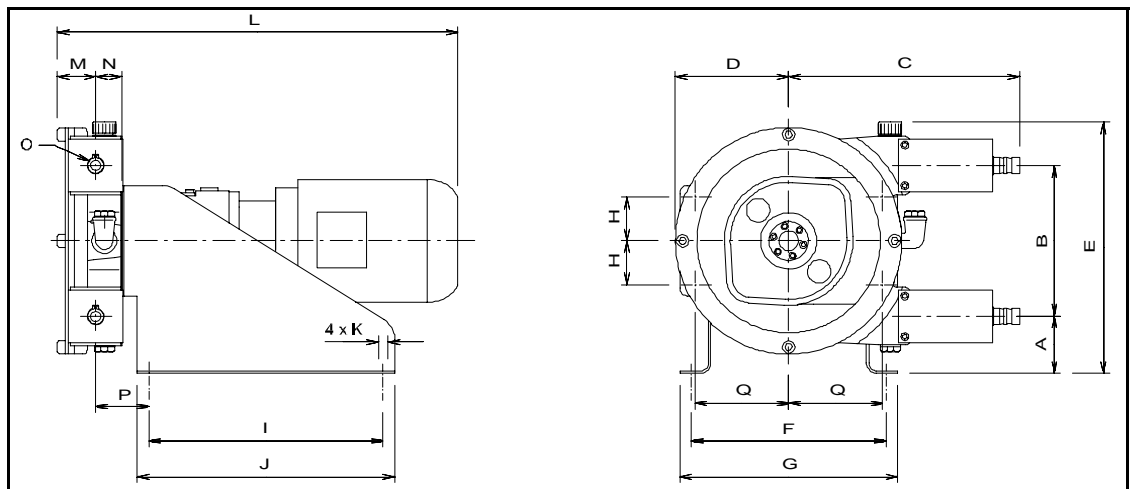

- Continuous
- *Intermittent
- Forbidden

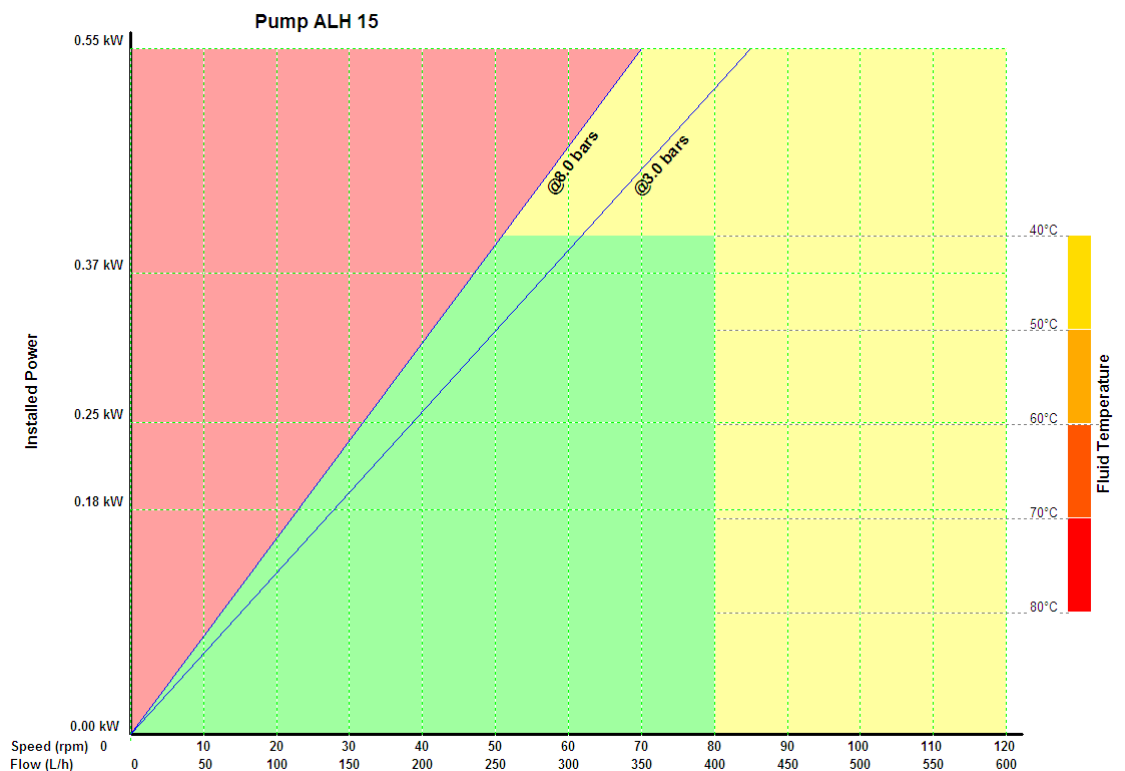

ALBIN PUMP SAS
 ZAC de Fontgrave
 F-26740 Montboucher
 Tél: + 33 4 75 90 92 92
 Fax: + 33 4 75 90 92 40
www.albinpump.fr
www.albinpump.com

*Intermittent use is 2 hours max. continuous duty followed by 1 hour stop